



**VERSION 8**

AIR DIVISION  
DEPARTMENT OF ENVIRONMENT

**2025**

**SERIES OF  
CONTINUOUS EMISSION MONITORING SYSTEM  
(CEMS) GUIDELINES**

**VOL. I :** GUIDELINES FOR THE INSTALLATION & MAINTENANCE OF CEMS FOR INDUSTRIAL PREMISES/FACILITIES

**VOL. II :** GUIDELINES FOR THE CEMS DATA INTERFACE SYSTEM (CEMS-DIS)

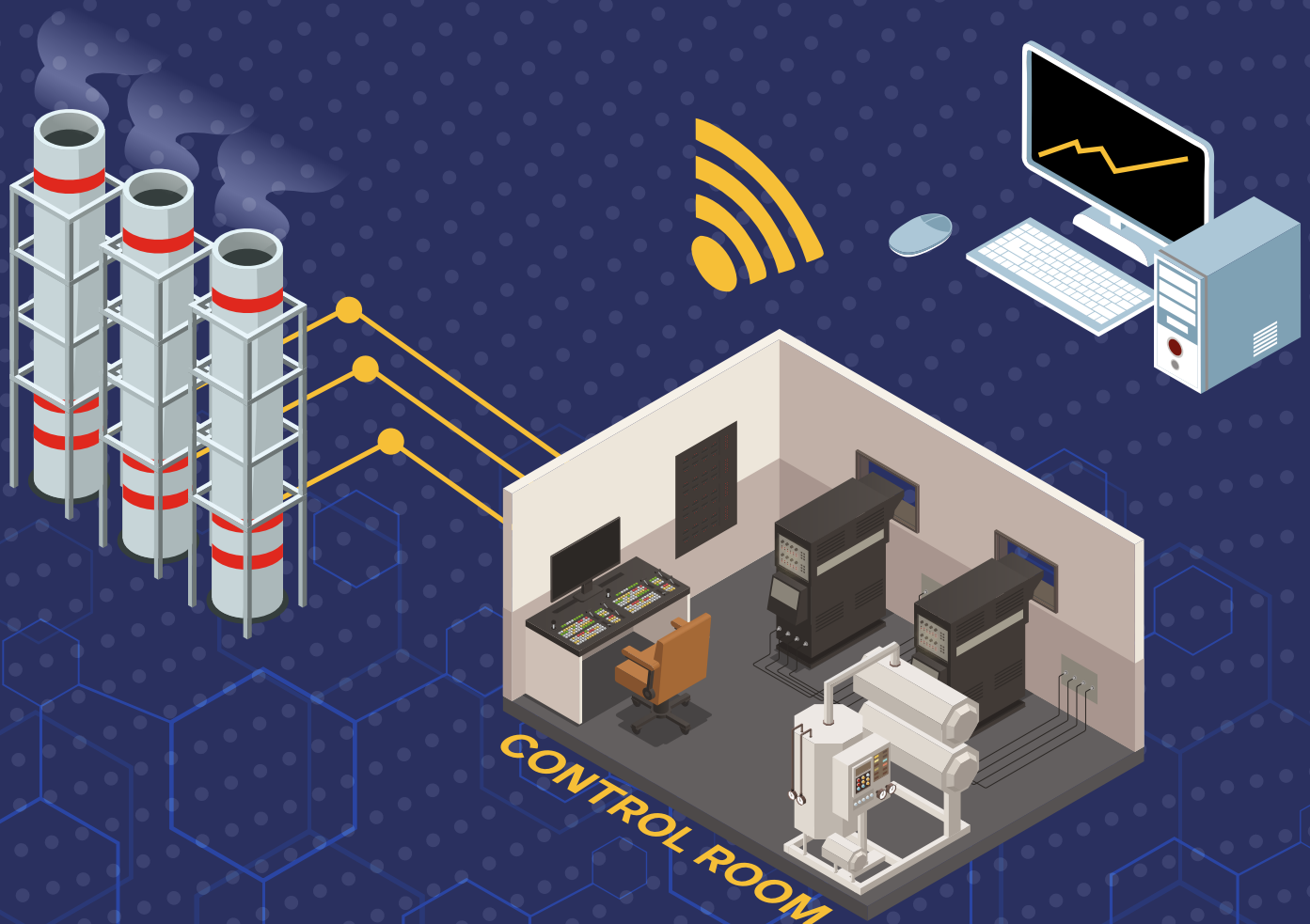





**VERSION 8**

AIR DIVISION  
DEPARTMENT OF ENVIRONMENT

**2025**

**SERIES OF  
CONTINUOUS EMISSION MONITORING SYSTEM  
(CEMS) GUIDELINES**

**VOL. I** : GUIDELINES FOR THE INSTALLATION & MAINTENANCE OF CEMS FOR INDUSTRIAL PREMISES/FACILITIES

**VOL. II** : GUIDELINES FOR THE CEMS DATA INTERFACE SYSTEM (CEMS-DIS)

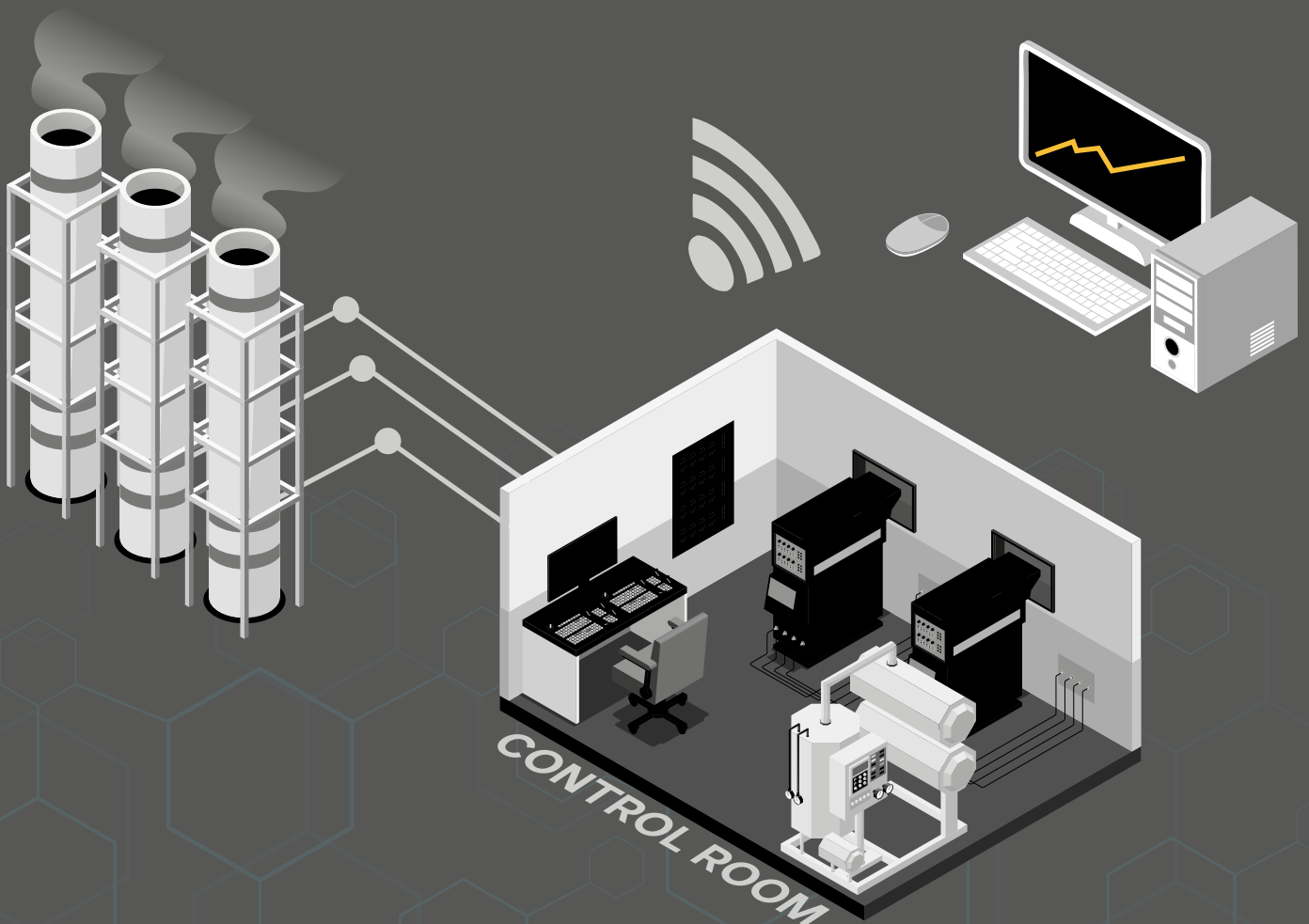

Published by:



**Department of Environment, Malaysia**

Department of Environment  
Ministry of Natural Resources and Environment Sustainability  
Level 1 - 4, Podium 2 & 3  
No.25, Wisma Petra, Precint 4  
Federal Government Administrative Centre  
62574 Putrajaya

**T:** 03 - 8871 2000

**F:** 03 - 8888 9987

**Hotline:** 1 - 800 - 88 - 2727

[www.doe.gov.my](http://www.doe.gov.my)

Copyright 2025

This publication may be reproduced in whole or in part and in any form for educational or non-profit purpose without special permission from the copyright holder; provided acknowledgement of the source is made and a copy is sent to the Department of Environment. No use of this publication may be made for resale or any other commercial purpose whatsoever without prior permission in writing from the Department of Environment, Malaysia

ISBN 978-967-2845-49-2

Designed and Printed by:  
Visual Print Sdn. Bhd.  
No. 47, 47-1, Jalan Damai Raya 1,  
Alam Damai, Cheras  
56000 Kuala Lumpur

# TABLE OF CONTENT

Foreword	1	<b>Chapter 4 - CEM System Requirements</b>	<b>30</b>
Acknowledgment	2	4.1 Design Specifications	30
Feedback	2	4.2 Installation Specifications	34
Record of Amendments	2		
List of Abbreviations	3		
<b>Chapter 1 - Introduction</b>	<b>4</b>	<b>Chapter 5 - CEMS Quality Assurance Programs</b>	<b>36</b>
1.1 Introduction	4	5.1 Quality Assurance Programs	36
1.2 Objectives	4	5.2 Functional Test	37
1.3 Definitions	5	5.3 Calibration and Variability Test (QAL2-CVT)	38
		5.4 QAL2 Implementation	45
<b>Chapter 2 - Applicability</b>	<b>9</b>	5.5 QAL3 – On-Going Performance Monitoring	46
2.1 Applicability	9	5.6 Annual Surveillance Test	48
2.2 Emission Limit Value	9	5.7 Modifications, Upgrading or Repairs of CEMS	49
2.3 Valid Averages	12		
2.4 Legal Compliance	12	<b>Chapter 6 - Reporting</b>	<b>50</b>
2.5 Roles and Responsibilities	12	6.1 Record Keeping	50
2.6 Process Flow of CEMS	16	6.2 Reports	50
		<b>Reference</b>	<b>51</b>
<b>Chapter 3 - CEM System</b>	<b>18</b>		
3.1 Sampling Systems	18		
3.1.1 Extractive	18		
3.1.2 In-Situ	19		
3.2 Selection of CEM Sampling System	20		
3.3 CEMS Analyzers	21		
3.4 Data Acquisition Handling System (DAHS/DAS)	28		
3.5 Data Availability	29		

# Appendix

- Appendix 1 Functional Test Audit Guidance
- Appendix 2 Calibration and Variability Test Report / Annual Surveillance Test Guidance
- Appendix 3 CEMS Evaluation Yearly Report Format
- Appendix 4 CEMS Failure and Excess Emission Report Format
- Appendix 5 Monthly CEMS Data Analysis Report

## Figures

- Figure 2.1 Summary of CEMS installation & operation process flow
- Figure 3.1 Example of Extractive CEMS
- Figure 3.2 Example of In Situ CEMS
- Figure 3.3 Basic Extractive CEM system
- Figure 3.4 Typical in-situ and In-situ Point CEM System
- Figure 3.5 Summary of the CEM sampling method recognized by DOE
- Figure 3.6 CEM system control and DHAS functions
- Figure 4.1 Sampling probe location
- Figure 4.2 Measurement point for Point CEMS
- Figure 4.3 Measurement point for Path CEMS
- Figure 5.1 The Sequence of Quality Assurance and Quality Control activities for CEMS
- Figure 5.2 Flow Chart for Calibration & Variability Test of CEMS
- Figure 5.3 Reference method traverse points on a measurement line

## Tables

- Table 2.1 Emission Limit Value for some of the source sectors required CEMS
- Table 2.2 Roles and Responsibilities of CEMS
- Table 3.1 Comparison of features between extractive and in-situ system
- Table 3.2 Typical analytical techniques used in CEM system
- Table 3.3 Substance to monitor with applicable monitoring technique
- Table 4.1 Certified ranges for CEMS installed at gas turbine using hydrocarbon gas fuel
- Table 4.2 Certified ranges for CEMS installed at waste incineration plant
- Table 4.3 Requirement on the measurement of uncertainty of CEMS
- Table 5.1 Outline for a CEM System Quality Assurance Manual
- Table 5.2 The requirements for functional tests
- Table 5.3 Situations arise during parallel measurement and procedure to determine calibration function
- Table 5.4 Generating calibration functions for NO<sub>x</sub>
- Table 5.5 Related variability test equation and criteria
- Table 5.6 Performance Criteria of Gases and Particulate CEMS



# FOREWORD

Assalamualaikum w.b.t & Salam Sejahtera,

In a world increasingly mindful of its ecological footprint, the Environmental Quality Act, 1974, stands as a crucial pillar for Malaysia's environmental stewardship. Central to this act's effectiveness is the mandate for industries to operate responsibly, which is why the Department of Environment (DOE) is proud to present the revised Volume I: Guidelines for the Installation & Maintenance of Continuous Emission Monitoring System (CEMS) and Volume II: Guideline for the Continuous Emission Monitoring Systems - Data Interface Systems (CEMS-DIS) Version 8.0.

This updated guideline is not just a document; it is a vital tool designed to empower industries to become more transparent and self-regulatory in their environmental compliance. With the Environmental Quality Regulations (Clean Air) 2014 now requiring CEMS for specific industries, the need for accurate and reliable emission monitoring has never been more critical. This guide provides a comprehensive roadmap for all stakeholders; from plant operators to CEMS manufacturers and consultants, to ensure the

proper selection, installation, and operation of these systems.

By adhering to these guidelines, you are not just complying with the law; you are actively contributing to a cleaner, healthier environment for all Malaysians. The information within this guideline covering everything from CEMS technologies and design specifications to quality assurance programs is designed to standardize practices and ensure that the data reported is reliable and transparent.

Thank you to all the experts and stakeholders who contributed their invaluable insights to this publication. Your dedication helps us all move forward in our shared mission of environmental protection.

**Dato' Wan Abdul Latiff Bin Wan Jaffar**  
Director General  
Department of Environment

# Acknowledgments

This guideline has been prepared to fulfill the Regulation 17 of Environmental Quality (Clean Air) Regulations 2014 (CAR 2014) enforced by the Department of Environment Malaysia. The following individuals were centrally involved in the development and review of this document:

## DOE CEMS/PEMS Technical Committee

Dr. Norhazni binti Mat Sari  
 Nor Aziah binti Jaafar  
 Haji Rosli bin Zul  
 Mukhtaroh binti Osman  
 Dasuki Loo bin Abdullah  
 Dr. Ts. ChM. Anuar bin Ishak  
 Noor Suffianhadi bin Ramly  
 Hazimi bin Hamid  
 Dr. Ezahtul Shahreen binti Ab. Rahman  
 Hapsah binti Mohamad  
 Farah Diyana binti Rusli  
 Muhammad Yuzwan bin Muhammad Yunos  
 Zazuraini binti Zolzaini  
 Nurul Syazreen binti Razali  
 Aizura binti Muslim  
 Siti Izdahafifi binti Herdiyanto Saputra  
 Normahyuni binti Muhammad  
 Muhammad Hairi bin Nordin

## Feedback

Any comment or suggestion for improvements to this document shall be addressed to the Air Division, Department of Environment Malaysia, Putrajaya. All supplementary to this guideline can be retrieved at [www.doe.gov.my](http://www.doe.gov.my).

## Record of Amendments

Version	Date	Amendment
6.0	6 Nov 2009	1 <sup>st</sup> publication of Vol. 1: CEMS Guidelines for the Installation & Maintenance of CEMS for Industrial Premises/Facilities together with Vol 2: Guidelines for the Continuous Emission Monitoring System – Data Interface System (CEMS-DIS).
7.0	21 Jun 2019	2 <sup>nd</sup> publication of Vol. 1: CEMS Guidelines with a major rewrite incorporating the previously published document. These changes reflect the gazettement of Clean Air Regulation 2014 and the adoption of new CEMS requirement by DOE.
8.0	29 October 2025	3 <sup>rd</sup> publication of Vol. 1: CEMS Guidelines for the Installation & Maintenance of CEMS for Industrial Premises/Facilities with some revisions and information updates together with Vol 2: Guidelines for the Continuous Emission Monitoring System – Data Interface System (CEMS-DIS).



# List of Abbreviations ▶

AST	Annual Surveillance Test
CAR, 2014	Environmental Quality (Clean Air) Regulations, 2014
CEMS	Continuous Emission Monitoring System
CO	Carbon Monoxide
CO <sub>2</sub>	Carbon Dioxide
CVT	Calibration & Variability Test
DAS	Data Acquisition System
DIS	Data Interface System
DOAS	Differential Optical Absorption Spectroscopy
DOE	Department Of Environment
ELV	Emission Limit Value
EQA	Environmental Quality Act
FID	Flame Ionization Detector
FTIR	Fourier Transform Infrared
GFC	Gas Filter Correlation
HCL	Hydrogen Chloride
HF	Hydrogen Fluoride
IR	Infrared
MCERT	Monitoring Certification Scheme
NDIR	Non-Dispersive Infrared
NDUV	Non-Dispersive Ultraviolet
NMVOC	Non-Methane Volatile Organic Compound
NO	Nitrogen Oxide
NO <sub>2</sub>	Nitrogen Dioxide
O <sub>2</sub>	Oxygen
OGPM	On-Going Performance Monitoring
PAS	Photoacoustic Spectroscopy
PM	Particulate Matter
QA	Quality Assurance
QAL	Quality Assurance Level
QAP	Quality Assurance Plan
SO <sub>2</sub>	Sulphur Dioxide
SO <sub>3</sub>	Sulphur Trioxide
SRM	Standard Reference Method
TLD	Tuneable Laser Diode
TOC	Total Organic Carbon
TUV	German Technical Inspection and Monitoring Union
VCR	Valid Calibration Range

# Chapter 1 ►

## Introduction

### 1.1 Introduction

1.1.1 Continuous Emission Monitoring Systems (CEMS) refers to a packaged of equipment required for determination of emission pollutant (gases, particulates, or smoke opacity) which may include sampling system, analyzer or monitor, other auxiliary equipment and integrated with a data acquisition system. The continuous measurement of emission pollutant either gases, particulates, or smoke (opacity) emitted from stationary source will provide a continuous record of air pollution control equipment performance and will determine compliance with applicable emission limit values (ELV).

1.1.2 CEMS are required to be installed at certain facilities which are subjected under the Environmental Quality (Clean Air) Regulations 2014 (CAR 2014) or at any activities which deem are required to be installed (e.g. terms and conditions of EIA report approval, licensed prescribed premise, problematic facilities, latest formal written directive from DOE etc.) by Department of Environment Malaysia (DOE) jurisdiction under the Environmental Quality Act (EQA) 1974.

1.1.3 For the plant operator, a proper installation and operation of CEMS can provide information about the operation of key processes and describe the effectiveness of the air pollution control techniques. Having the ability to examine various aspects of the facility's operation, CEMS will be able to provide user the opportunity to make any critical adjustments for process optimization and cost reduction. Additionally, CEMS is proven to be an important documentation to show compliance status especially whenever there is high time of public concern about air pollution.

1.1.4 For regulatory agencies, the data provided by a CEMS are used to supplement on-site visit, to identify problem sources, and to determine if source emission limits and proper operation and maintenance requirements are being met. With a better picture of actual

emissions, the regulator's ability to develop strategies for future program directed at emissions reduction can be enhanced.

1.1.5 The main goal of both the plant operators and the regulatory agency is to obtain accurate and reliable information about stack emission, as well as to ensure that no air pollution occurs that can cause serious health impact, and the environment is constantly preserved.

### 1.2 Objectives

1.2.1 The overall aims of this guidance document are to provide information, and an understanding of CEMS, their application as well as to provide reliable CEMS data and enable plant operators to demonstrate compliance with the regulatory requirements. Installation of CEMS is an exercise requiring investment and commitment by the plant operators. Hence, the objectives of this guidance document are to:

- a) Define the DOE approach and requirements for CEMS;
- b) Provide the plant operator guidance on how these can be achieved, provide information and explanations on CEMS, the CEMS various technologies, best practices, and its implementation; and
- c) Provide guidance on the supporting activities needed to sustain the CEMS operation through periodic calibration and maintenance.

Basically, this guideline is comprising important elements listed below:

- a) Applicability of CEMS installation for Industrial sectors (or activities) as subjected under the CAR 2014.
- b) CEMS technology, equipment, and applicable monitoring techniques.
- c) CEMS specifications including design and installation requirements (QAL1).
- d) Application procedures for CEMS installation.
- e) Quality Assurance (QA) including QAL2-CVT, QAL3-OGPM, and AST of CEMS and reporting requirement.



## 1.3 Definitions

<b>95% confidence interval</b>	Is a range of values (emission value) that can be 95% certain contains the true mean of the population.
<b>Annual Surveillance Test (AST)</b>	Is to check whether the calibration function determined during the Calibration and Variability Test is still valid. The AST consists of the same functional tests as those used in QAL2-CVT.
<b>Audit</b>	An as-found accuracy assessment of CEMS components using an authoritative certified standard.
<b>Calibration error</b>	The difference between the response of the pollutant, diluent to the known value of the appropriate reference material; gas, filter, or signal.
<b>Calibration</b>	Determination of a calibration function with (time) limited validity applicable to a CEMS at a specific measurement site.
<b>Calibration function</b>	Linear relationship between the values of the SRM and the CEMS with the assumption of a constant residual standard deviation.  Note: The calibration function describes the statistical relationship between the starting variable (measured signal) of the measuring system and the associated result of measurement (measured value) simultaneously determined at the same point of measurement using a SRM.
<b>CEMS</b>	The total equipment required to sample, condition, analyze and provide a permanent and continuous data record of pollutant concentration. This includes the equipment necessary to perform the required routine calibration, data acquisition and data interface system for the data be able transferred online to DOE.
<b>CEMS Tester</b>	Registered or certified CEMS tester approved and recognized by DOE to perform the SRM for the Calibration and Variability Test and Annual Surveillance Test procedures.
<b>CEMS Manufacturer</b>	Companies that make CEMS products, supplying, achieving, and maintaining certification of CEMS to the applicable certification performance standards.
<b>CEMS Consultant</b>	Recognized and registered companies with DOE that supply, install, commission, and maintain CEMS appropriately based on their certification at industrial premises. They are also responsible for giving advice on CEMS requirements and compliance to the plant operator.
<b>Centroidal Area</b>	A concentric area that is geometrically such as the stack or duct cross section and is no greater than one (1) percent of the stack or duct cross-sectional area.
<b>Certification Range</b>	Range over which the CEMS is tested and certified for compliance with the relevant performance criteria.  Note: QAL1 Certification range is always related to the daily ELV.
<b>Correlation</b>	Mathematical relationship for correlating the output from your CEMS to concentration, as determined by the Standard Reference Method. The correlation is expressed in the measurement units that are consistent with the measurement conditions of CEMS.
<b>Data Acquisition System</b>	The component of the CEMS is designed to interpret and convert individual output analogue signals from pollutant concentration monitors, flow monitors, diluent gas monitors and other components of the monitoring system into digital numeric values that can be interpreted by computer to produce a permanent continuous record of the measurement and desired parameters.

<b>Diluent Gas</b>	A major gaseous constituent in a gaseous pollutant mixture. For combustion sources, CO <sub>2</sub> and O <sub>2</sub> are the major gaseous constituents of interest. 2 <sup>nd</sup> Schedule and 3 <sup>rd</sup> Schedule of Clean Air Regulation 2014 specified reference gas applicable for different types of activities/facilities.
<b>Downstream</b>	The direction of flue gas travel from the emission sampling port towards stack outlet.
<b>Downtime</b>	Time periods of source operation in which invalid CEMS data or no data is collected due to any appropriate reason. This includes periods of documented QA activities, calibration, preventive maintenance, malfunction, audits which result in periods of invalid data and 'out-of-control' periods.
<b>Emission Limit Value (ELV)</b>	The mass, expressed in terms of certain specific parameters, concentration and/or level of an emission, may not be exceeded during any one or more periods of time. ELV applies based on the CAR 2014 or from DOE directives, notices, licenses, or approval under EQA 1974. It can be stated as concentration limits expressed as half-hourly average, and daily average. For compliance under the CAR 2014, no daily average exceeds ELV, and no half hourly average exceeds 2 times ELV.
<b>Excess Emission</b>	For CEMS, it is an exceedance of the applicable emission limit value (ELV) as indicated by valid measurement of the monitor and reported using the appropriate significant digits, units and averaging period that directly corresponds to the applicable emission limit.
<b>Extractive Monitoring System</b>	A system that withdraws gas samples from the stack and transports the sample to the analyzer.
<b>Functional Test</b>	The functional tests are a series of checks carried out on the CEMS and must be performed before Calibration and Variability Test and Annual Surveillance Test.
<b>Hydraulic Diameter</b>	Calculated value is used to determine the upstream and downstream distances for locating flow to pollutant concentration monitors in flues, ducts, or stacks with rectangular cross-sections.  The characteristic dimension of a duct cross section is defined by: $D_h = \frac{4 \times \text{area of sampling plane}}{\text{Perimeter of sampling plane}}$
<b>Industrial Premises / Facility</b>	Any applicable stationary air contaminant emission source (institutional, commercial, industrial structure, installation, plant, source, or building) required by the DOE to operate a CEMS.
<b>In-Situ Monitor</b>	CEMS design that measures source-level gas emissions directly inside a stack or duct at actual conditions.
<b>Inspection</b>	A check for the conditions that is likely to affect the reliability of the system. E.g. of these conditions would include the following: damage to system components, leaks, low flow conditions in the sample transport system, alarms, adequate supply of consumables, etc.
<b>Internal Diameter</b>	The inner diameter of stack/chimney.
<b>Leak Check</b>	A test to determine any leakage on the entire CEMS sampling system.
<b>Linearity Test</b>	Systematic deviation, within the range of applications, between the accepted value of a reference material applied to the measuring system and the corresponding result of measurement produced by the calibrated measuring system.
<b>Maintenance Interval</b>	Maximum admissible interval of time for which the performance characteristics remain within a pre-defined range without external servicing, for example refill, calibration, adjustment.

<b>Malfunction</b>	Any sudden, infrequent, and not reasonably preventable failure of any part of the CEMS that is caused by the equipment to function outside established design and/or performance specifications. Failures that are caused in part by poor maintenance or careless operations, in the opinion of DOE, are not considered malfunction.
<b>Measured Signal</b>	Output from a CEMS in analogue or digital form is converted into the measured value with the aid of the calibration function.
<b>Measurement Range</b>	The set of values that the CEMS can measure, from the lower detection limit (i.e. near zero) to a set upper limit.
<b>Normal load</b>	Most frequently used load level over the past four (4) representative operating quarters. For new unit/facility or if no historical load data are available, designate the normal load based on the expected or projected manner of operating the unit. The unit shall be expressed either in unit megawatt (electrical output), lb/hr of steam load or mmBtu/hr (thermal output), or in cfm or m <sup>3</sup> /hr of air flow rate (not produce electrical or thermal output)
<b>On-going Performing Monitoring (QAL3-OGPM)</b>	Procedures to ensure that the CEMS remains within the required specifications during continuous use. It is achieved by requiring the plant operator's personnel (competent person) to regularly measure the drift and precision on the maintenance interval of the CEMS.
<b>Output CEMS</b>	Reading, or digital or analogue electrical signal generated by a CEMS in response to an emission substance.
<b>Paired measurement</b>	Simultaneous recording of results of measurement at the same measurement point using two CEMS of identical design.
<b>Path CEMS</b>	CEMS that measures the gas concentration along a path greater than 10 percent of the equivalent diameter of the stack or duct cross section.
<b>Calibration and Variability Test (QAL2-CVT)</b>	Consist of a set of functional tests to check that the CEMS are operating in a satisfactory manner and a set of standard reference method (SRM) repetitions as a means of verifying the performance of the CEMS, and calibrating them, if necessary, by applying a calibration function.
<b>Plant Operator</b>	An industrial company which is responsible for the management and operation of their facility, and required to install, operate, and maintain CEMS.
<b>Point CEMS</b>	CEMS that measures the gas concentration either at a single point or along a path equal to or less than 10 percent of the equivalent diameter of the stack or duct cross section.
<b>Quality Assurance</b>	An integrated system of management activities involving planning, implementation, assessment, reporting and quality improvement to ensure that a process, item, or service is of the type and quality needed and expected by the end user.
<b>Quality Assurance Plan (QAP)</b>	A formal document describing in comprehensive detail the necessary quality assurance procedures, quality control activities and other technical activities that need to be implemented to ensure that the results of the work performed will satisfy the stated performance or accepted criteria.
<b>Quality Control</b>	The overall system of technical activities that measure the attributes and performance of a process, item or service against defined standards to verify that they meet the specifications established by the customer, operational techniques and activities that are used to fulfill the need for quality.

<b>Reference Material</b>	Certified materials, substances or mixture of substances, with a known composition within specified limits as provided by the CEMS manufacturer. For example:  Gas: Concentration shall be 80% - 100% of 2.5 times of ELV Dust: As provided by the CEMS supplier/manufacturer
<b>Reference Method Sampling Location</b>	The location at source's exhaust stack/chimney to collect manual standard reference method data to assess CEMS.
<b>Response Time</b>	Time interval between the instant of a sudden change in the value of the input quantity to a CEMS and the time as from which the value of the output quantity is reliably maintained above 90 % of the correct value of the input quantity.
<b>Source Shutdown</b>	The cessation of operation of an emission source for any purpose.
<b>Source Start Up</b>	The start in operation of an emission source for any purpose.
<b>Span drift</b>	Change in CEMS reading at the span point over the maintenance interval.
<b>Span Level/Value</b>	A design value that represents an estimate of the highest expected value for a parameter, based on the applicable emission limit. Span is calculated as a percentage range of the emission limit.
<b>Standard Condition</b>	A temperature of 273.15°K and an atmospheric pressure of 101.3 kPa.
<b>Standard Reference Methods (SRM)</b>	Any approved method of sampling and analysis of pollutants as authorized by the Director General of DOE as mentioned in Regulation 23, Clean Air Regulations 2014.
<b>Synthetic Air</b>	Mixture of pure Oxygen (20.9%) balanced Nitrogen.
<b>Uncertainty</b>	Parameter associated with the result of a measurement, that characterizes the dispersion of the values that could reasonably be attributed to the measurand.
<b>Upstream</b>	The direction of flue gas travel from the main stack inlet towards emission sampling port.
<b>Valid Calibration Range</b>	Acceptable region between the limits within which a quantity is measured, received, or transmitted, expressed by stating the lower and upper range values.
<b>Valid Data</b>	Any representative data average that meets the validation criteria.
<b>Zero &amp; Span Check</b>	Record of the CEMS response against a known concentration of span and zero gases. No calibration and adjustments involved.
<b>Zero Gas</b>	Gas mixture is used to establish the zero point of a calibration curve when used with a given analytical procedure within a given calibration range.
<b>Zero Point</b>	Specified value of the output quantity (measured signal) of the measuring CEMS and which, in the absence of the emission substance, represents the zero crossing of the CEMS characteristic

# Chapter 2 ► Applicability

## 2.1 Applicability

This guideline is applicable to any industrial premise/ facility that is required by regulation, permit, license, terms and conditions of EIA report approval or any latest written directive issued by DOE under the Environmental Quality Act 1974 (EQA 1974) to install, operate and maintain a CEMS for the purpose of continuously determining and reporting compliance with applicable emission limits or operating permits.

Under Regulation 17, CAR 2014 each industrial premise/ facility shall carry out continuous emission monitoring for specified parameters as required in Regulation 12 and as listed in the 2<sup>nd</sup> Schedule and 3<sup>rd</sup> Schedule of CAR 2014. CEMS requirement is as in addition to the periodic monitoring mentioned in Regulation 16 and as specified in the Second and Third Schedule of CAR 2014. The measuring devices installed for the purpose of continuous emission monitoring must comply with the specifications as determined by the Director General. The specifications are referring to Volume I and Volume II of series of CEMS Guidelines.

## 2.2 Emission Limit Value

2.2.1 Emission Limit Value (ELV) for stationary sources are as prescribed in the EQA 1974 under the CAR 2014 and its subsequent revisions.

2.2.2 These regulations and subsequent revisions as mentioned in 2<sup>nd</sup> Schedule and 3<sup>rd</sup> Schedule of CAR 2014 specify activities and pollutants that are to be monitored continuously and their limit values which are:

- a) Fuel burning equipment, incinerator and crematorium not covered by the 1<sup>st</sup> Schedule with total dust emitted of 2.5 kg/hour or more;
- b) Fuel burning equipment (1<sup>st</sup> Schedule); Heat and power generation;
- c) Production and processing of ferrous metals (iron & steel mills);
- d) Production and processing of non-ferrous metals with a capacity  $\geq 0.5$  tons per day for lead or cadmium or  $\geq 2$  tons per day for other metals.
- e) Oil and gas industries: Refineries (all sizes); Natural gas processing and storage, storage and handling of petroleum products;
- f) Non-metallic (mineral) industry: Cement production (all sizes); Manufacture of glass including glass fibre with a melting capacity  $\geq 1$  ton of product per day; Manufacture of ceramic products by firing, in particular roofing tiles, bricks, refractory bricks, tiles, stoneware, or porcelain with a production capacity  $\geq 10$  tons of product per day; and
- g) Waste incinerators in all sizes.

2.2.3 In addition to the above listed activities in Para 2.2.2, Regulation 12 (opacity) of CAR 2014 requires CEMS installation if premise has potential to emit 2.5 kg/hr or more of dust or has potential to emit smoke darker than shade No. 2 of Ringlemann Chart.

2.2.4 The segmented parameters for the above listed source of activities required CEMS are as outlined briefly in **Table 2.1**.

**Table 2.1: ELVs for some of the source sectors required CEMS**

Source Activity	Source/Capacity/ Fuel Type	Gas Reference Content	Pollutants	Limit Value (mg/m <sup>3</sup> )
Fuel Burning Equipment	• Any Fuel (If total dust emission is 2.5 kg/hr or more or emit smoke darker than Shade No. 2 of Ringlemann Chart)	-	Opacity	20%
Fuel Burning Equipment	Solid	CO <sub>2</sub> : 12%	Total PM where dust load emitted ≥ 2.5kg/h	150
Heat and Power Generation	Boilers > 10MWe (Liquid and Solid Fuel)	O <sub>2</sub> : 6% - solid fuel O <sub>2</sub> : 3% - liquid fuels	SO <sub>2</sub> NO <sub>2</sub> CO Total PM	500 500 200 50
	Boilers > 10MWe (Gas Fuel)	O <sub>2</sub> : 3% - gas fuel	NO <sub>2</sub> CO	350 50
	Combustion Turbines > 10MWe (Gas Fuel)	O <sub>2</sub> : 15%	NO <sub>2</sub> CO	150 100
	Combustion Turbines > 10MWe (Liquid Fuel)	O <sub>2</sub> : 15%	NO <sub>2</sub> CO	200 100
Production and Processing of Ferrous Metals (Iron and Steel Mills)	Sinter plants (waste gas from the sintering belt)	-	SO <sub>2</sub> NO <sub>2</sub> Total PM	500 400 50
	Coke ovens	O <sub>2</sub> : 5%	Total PM	10
	Blast furnace (regenerator)	O <sub>2</sub> : 3%	Total PM	50
	Basic oxygen furnace (converter gas)	-	Total PM	50
	Electric arc furnaces	-	Total PM	50
Production and processing of non-ferrous metals with a capacity. > 0.5 tons per day for lead or cadmium or > 2 tons per day for other metals.	Sinter plants (waste gas from the sintering belt)	-	SO <sub>2</sub> NO <sub>2</sub> Total PM	500 400 50
	Production of copper and zinc		Total PM	20
	Production of lead		Total PM	10
	Primary aluminium		SO <sub>2</sub> Total PM	100 10
	Secondary aluminium		Total PM	10
	Smelting, alloying and refining of aluminium		Total PM	10
	Smelting, alloying and refining of other non-ferrous metals		Total PM	5

Source Activity	Source/Capacity/ Fuel Type	Gas Reference Content	Pollutants	Limit Value (mg/m <sup>3</sup> )
Oil and gas industries: Refineries (all sizes); Natural gas processing and storage; storage and handling of petroleum products	Catalytic cracking		Total PM SO <sub>2</sub>	40 1200
	Calcination		Total PM	40
Non-metallic (mineral) industry Cement production (all sizes) Manufacture of glass including glass fibre with a melting capacity ≥ 1 ton of product per day; Manufacture of ceramic products by firing, roofing tiles, bricks, refractory bricks, tiles, ceramic glass, stoneware or porcelain, with a production capacity ≥ 10 tons of product per day	Cement kiln	O <sub>2</sub> : 10%	NO <sub>2</sub> Total PM	800 50
	Glass furnaces	O <sub>2</sub> for: Flame heated glass melting furnaces – 8%  Flame heated pot furnaces and day tanks furnaces - 13%	SO <sub>2</sub> NO <sub>2</sub> Total PM	800 800 50
	Rotary furnaces for the manufacture of hard quicklime or sintering dolomite		NO <sub>2</sub> Total PM	1500 50
	Ceramic furnaces	O <sub>2</sub> : 17%	Total PM; where dust load emitted ≥ 2.0kg/jam	50
Chemical and Petrochemical Industry	*Thermal Oxidizer	O <sub>2</sub> : 11%	NO <sub>2</sub> NH <sub>3</sub> SO <sub>2</sub> TPM Opacity	700 76 100 50 20%
Waste incinerator	• Any fuel Fuel burning equipment that uses waste or schedule waste or byproduct as fuel need to comply with this ELV	O <sub>2</sub> : 11%	Total PM NMVOC as Total C HCl HF SO <sub>2</sub> NO <sub>2</sub> CO	100 10 40 1 50 200 50

**Note:**

- Unless stated in the Clean Air Regulations, requirement of CEMS installation for thermal oxidizer at chemical and petrochemical industry is upon DOE written directive\*.
- Emission shall be calculated in term of mass of pollutant per volume of the waste gases (expressed as mg/m<sup>3</sup>) at standard condition for temperature and pressure (STP) for dry gas (volume at 273K, 101.3 KPa).
- Averaging time of continuous monitoring for opacity shall be for one minute (Reg. 12(4), CAR 2014) and 30 minutes for other parameters.

## 2.3 Valid Averages

- 2.3.1 The sub-average period for determining half-hour average is 1-minute average. A valid half-hour average must contain at least 22 sub average data within half-hour period (75%).
- 2.3.2 A valid 1-minute average must contain valid data readings representing any 45 seconds over the previous 1-minute period.

## 2.4 Legal Compliance

- 2.4.1 For continuous emission monitoring, the limit values are complied with if the evaluation of the results for the operating period within any one calendar year shows that no daily average exceeds the ELV, and no half hourly average exceeds two (2) times of ELV. (Reg. 17(3) CAR 2014).

Example:

Daily average for TPM= 150 mg/m<sup>3</sup>

Half hourly average for TPM= 2 x 150 mg/m<sup>3</sup>  
=300 mg/m<sup>3</sup>.

- 2.4.2 The owner or occupier of the premises shall make evaluations of the continuous emission monitoring in a calendar year, whereby for each calendar day the daily mean value that relates to the daily operating time shall be derived from the half hourly mean values. (Reg. 17(4) CAR 2014).
- 2.4.3 The owner or occupier of the premises shall submit to the DOE the results of evaluations within three (3) months after the end of each calendar year, and such evaluation results are to be kept and maintained by the owner or occupier for at least 3 years. (Reg. 17(5) CAR 2014). Reporting is to be made to the state/branch DOE by using report format as in **Appendix 3**.
- 2.4.4 In the event where ELV standards exceed the prescribed limit values, the owner or occupier

of premises shall notify the DOE within 24 hours from the discovery of the excess emission. (Reg. 17(6) CAR 2014). Reporting is to be made to the state/branch DOE by using report format as in **Appendix 4**.

- 2.4.5 In the event a monitoring device fails to operate, the owner or occupier of premises shall notify the DOE not later than one hour from the occurrence of such failure. (Reg. 17(7) CAR 2014). Reporting is to be made to the state/branch DOE by using report format as in **Appendix 4**.

## 2.5 Roles and Responsibilities

- 2.5.1 The key parties in CEMS application are inclusive of CEMS manufacturer, CEMS consultant, plant operators and DOE as the regulatory agency. CEMS consultant in this regard is referring to CEMS supplier.
- 2.5.2 CEMS manufacturers shall ensure CEMS supplied to the appointed sole distributor/distributors/agent and plant operators are MCERT/TUV QAL-1 certified prior installation.
- 2.5.3 Installation of CEMS at industrial premise/facility requires prior application to DOE by the plant operator and shall be installed by a registered CEMS consultant as listed in the DOE website and DOE system for CEMS.
- 2.5.4 In order to verify that the CEMS has been installed correctly, verified, and calibrated, DOE registered CEMS tester is required to conduct performance audit of the CEMS after installation and also to conduct in regularly basis based on DOE requirement on this guideline.
- 2.5.5 **Table 2.2** listing the roles and responsibilities of CEMS manufacturers, consultants, testers, plant operators and DOE (regulator).

**Table 2.2 – Roles and Responsibilities of CEMS**

Roles	Responsibilities	Further Information
CEMS manufacturers	<ul style="list-style-type: none"> <li>Achieving and maintaining certification of CEMS to the applicable performance standards</li> <li>Appoint local CEMS consultant to supply and to install CEMS at plant operator's facility. Letter of appointment shall be issued to the appointed sole distributor or distributor or appointed agent.</li> <li>To provide a complete training of CEMS installation, operation, and maintenance to the appointed CEMS consultant. Training certificate shall be issued.</li> </ul>	<ul style="list-style-type: none"> <li>Certified CEMS requirements by DOE are discussed in sub-Chapter 4.1.</li> <li>CEMS manufacturer and consultant may same.</li> <li>Letter of appointment shall be presented during CEMS consultant registration process.</li> <li>A copy of training certificate shall be provided during CEMS consultant registration process.</li> </ul>
CEMS consultants	<ul style="list-style-type: none"> <li>To be registered with DOE.</li> <li>To supply DOE registered CEMS and complete with a proper documentation, in relevance to plant stack/chimney CEMS application.</li> <li>To give consultation and advice on CEMS requirement and compliance to plant operator.</li> <li>To ensure CEMS supplied design is as per QAL1 certificate and suitable with the plant process, flue gas characteristics, pollutants to be monitored, ELV and any other related criteria.</li> <li>To install and commission CEMS at plant operator's facility.</li> <li>To install CEMS in a manner which assures their integrity and correct operation to the required performance standards.</li> <li>To provide technical assistance and maintain after sales service to the plant operator on CEMS related matters and problems.</li> <li>When appropriate, cooperating with plant operators and CEMS tester to perform the functional test of CEMS.</li> <li>To ensure DOE System installed follows the requirement and CEMS data is transferred online to DOE without interruption.</li> <li>To provide training in operating and maintaining the installed CEMS for plant operator.</li> <li>To not undertake any job that is beyond CEMS consultant's competency.</li> <li>To ensure trained and competent personnel available to support plant operators</li> </ul>	<ul style="list-style-type: none"> <li>Registration as CEMS consultant and to register CEMS equipment through DOE System for CEMS.</li> <li>Shall ensure the CEMS design requirements (Sub-Chapter 4.1) and installation requirements (Sub-Chapter 4.2) are followed.</li> <li>Refer Guidelines Volume II: Guideline for the Continuous Emission Monitoring System -Data Interface System (CEMS-DIS) for Industrial premises / Facilities.</li> </ul>

Roles	Responsibilities	Further Information
CEMS Tester	<ul style="list-style-type: none"> <li>Register as CEMS audit tester with DOE. Registration criteria is as specified in the Guidelines and Criteria For Registered CEMS Tester published by DOE.</li> <li>CEMS Tester shall only conduct CEMS testing on CEMS that is not installed by them or company with the same stakeholder, including their subsidiaries.</li> <li>When appropriate, co-operating with plant operator and CEMS consultant to conduct functional test.</li> <li>A competent CEMS tester (which company has the same registered CEMS brand and model) may conduct functional test should the site CEMS consultant is not available to conduct the test.</li> </ul>	<ul style="list-style-type: none"> <li>Registration as CEMS tester through DOE System for CEMS</li> </ul>
	<ul style="list-style-type: none"> <li>Notifying the plant operator on the responsibility to ensure the functional test are performed before each QAL2 and AST. QAL2 or AST shall not be proceeded if functional test failed, and no correction action is taken.</li> <li>Performing the SRM for the QAL2 and AST procedures.</li> <li>Reporting the results of the FT, QAL2 and AST to plant operator and DOE.</li> <li>If the faults are judged to influence the quality data, then the plant operator shall carry out the necessary corrective and preventive actions.</li> </ul>	<ul style="list-style-type: none"> <li>Refer to Chapter 5 – Quality Assurance Program. All test required are discussed in this Chapter 5.</li> <li>Refer to Chapter 6- Reporting and related reporting format as in Appendixes.</li> </ul>
Plant operator	<ul style="list-style-type: none"> <li>Register as CEMS Industry with DOE and to submit application of CEMS installation to DOE prior site installation.</li> <li>To install a registered and certified CEMS and supplied by a registered CEMS consultant.</li> <li>To ensure all CEMS Quality Assurance Program (Functional Test, QAL2, QAL3 and AST) are conducted.</li> <li>To ensure plant readiness prior CEMS testing.</li> <li>Ensuring that the functional tests are performed before each QAL2 and AST with the presence of CEMS consultant.</li> <li>To appoint a registered CEMS tester to conduct QAL2 and AST.</li> </ul>	<ul style="list-style-type: none"> <li>Registration as Industry and apply CEMS installation through DOE system for CEMS.</li> <li>Appoint CEMS tester approved by DOE (except for QAL3 if not required).</li> </ul>

Roles	Responsibilities	Further Information
Plant operator	<ul style="list-style-type: none"> <li>Performing QAL3 procedures based on the maintenance interval period stated in the MCERT/TUV or as recommended by the CEMS consultant, but not longer than interval specified in the MCERT/TUV certificate.</li> <li>Submission of QAL2, QAL3 and AST reports to DOE through DOE System for CEMS</li> <li>To monitor emission compliance through CEMS reading and ensure full compliance to CAR 2014.</li> <li>Report to DOE, In the event where ELV exceeds or CEMS fails to operate.</li> <li>To keep spare parts for service, maintenance, repair, and replacement of CEMS components or systems. CEMS reference materials shall be made available during CEMS testing.</li> </ul>	<ul style="list-style-type: none"> <li>Plant owner may appoint competent personnel (CEMS consultant, plant maintenance team, etc) to perform Preventive Maintenance (Zero/ Span drift check, consumable parts replacement, etc).</li> <li>Plant owner may appoint CEMS Tester to perform QAL3 (visual check, drift check, graph plotting, corrective action requirement).</li> <li>Refer to Chapter 6- Reporting and related reporting format as in Appendixes.</li> <li>Emission complies to CAR 2014 as mentioned in Table 2.1 and refer to sub-Chapter 2.3 and 2.4 for CEMS legal compliance requirement.</li> <li>Refer to Chapter 6- Reporting and related reporting format as in Appendixes.</li> </ul>
DOE	<ul style="list-style-type: none"> <li>To develop policy related to CEMS requirement and update the stakeholders.</li> <li>To specify technical requirements of CEMS required by DOE and to develop guidance document as reference.</li> <li>Register CEMS consultant, CEMS equipment and CEMS tester.</li> <li>To monitor and assess registered CEMS consultant and CEMS tester to maintain registration and on-going assessment.</li> <li>To monitor and assess plant operator compliance through enforcement.</li> <li>Providing guidance and facilitation towards compliance.</li> </ul>	<ul style="list-style-type: none"> <li>Assessment and registration via DOE System for CEMS</li> <li>CEMS data will be monitored by using DOE System for CEMS</li> </ul>

## 2.6 Process Flow of CEMS Installation

- 2.6.1 The process of installing and operating CEMS at plant operator's facility begin with registering the CEMS consultant.
- 2.6.2 The purpose of CEMS consultant registration is to identify companies specializing in providing the following services: -
- a) Volume I - Installation and maintenance of Continuous Emission Monitoring System (CEMS) and CEMS Data Acquisition System (CEMS-DAS) at industrial premises; and/or
  - b) Volume II - Installation and maintenance of CEMS Data Interfacing System (CEMS-DIS) at industrial premises for data transmission from CEMS-DAS to DOE system for CEMS
- 2.6.3 CEMS consultant is required to provide information about CEMS equipment to the DOE to get registered. Only CEMS equipment which meet the pre-set condition (details as discussed in Sub-Chapter 4.1) in this guideline will be registered under CEMS consultant. CEMS consultant and equipment registration shall be made via DOE system for CEMS
- 2.6.4 All industrial premises / facility (plant operator) which required to install new CEMS, major modifications and upgrading needs to provide information to the DOE on the details of CEMS design, installation and operational. Any CEMS supplied must obtain acknowledgement letter from DOE prior to any installation works in which the details of CEMS requirement are elaborated in **Chapter 4** of this guideline. Application of CEMS installation shall be made via DOE system for CEMS.
- 2.6.5 Any existing CEMS installed prior this guideline to which came into force and/or not obtain acknowledgement from DOE shall promptly proceed to register the system via DOE system for CEMS. The installed CEMS shall comply with the technical standards as specified in the **Chapter 4** of this guideline.
- 2.6.6 The process of CEMS data connection from premise to DOE system for CEMS will need to be executed by CEMS consultant upon success installation of CEMS by following steps and procedures as guided by DOE system for CEMS. The CEMS consultant shall ensure the connecting medium is developed based on the Guidelines Volume II: Guideline for the Continuous Emission Monitoring System-Data Interface System (CEMS-DIS) for Industrial premises/Facilities.
- 2.6.7 Any CEMS installation acknowledged by DOE and successfully transmitting data to DOE system for CEMS shall promptly conduct Calibration and Variability Test (QAL2-CVT) by appointing a third party registered CEMS Tester to conduct the test. The details of Calibration and Variability Test required is elaborated in **Chapter 5** of this guideline. CEMS data generated and sent to DOE from an unaudited CEMS is presumed invalid.
- 2.6.8 All CEMS data need to be transmitted directly from the industrial premise to DOE system for CEMS without using any intermediate or centralized server as a medium of temporary data storage prior transmission to DOE system for CEMS.
- 2.6.9 For CEMS continuous operation, Quality Assurance Plan (QAP) as specified by DOE must be implemented by plant operator. QAP activities include CEMS operational and maintenance, performance audit, training, and monitoring plan. All industrial premises / facility subjected to CEMS requirements shall notify the DOE as soon as possible should any changes are made to any part of a CEMS, including its Quality Assurance Program. These QAP will be further elaborated in **Chapter 5** of this guideline.
- 2.9.10 **Figure 2.1** summarizing the CEMS installation and operation process flow as mentioned in para 2.6.1 to 2.6.8. The application of these processes is reflected in the DOE system for CEMS, and the plant operator shall ensure all necessary exercises required are undertaken successfully.

**Figure 2.1 Summary of CEMS Installation and Operation Process Flow**

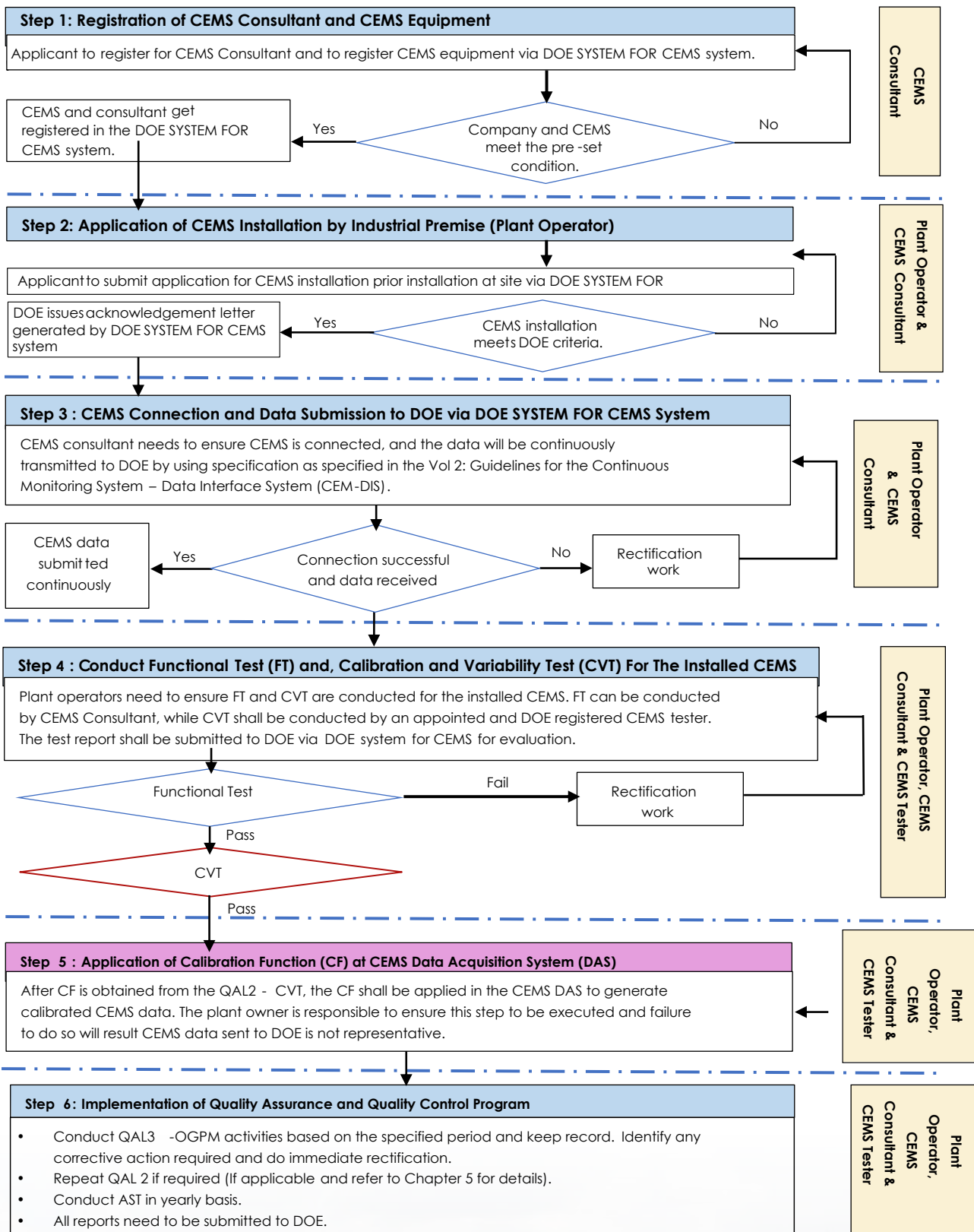

VOLUME 1: Guidelines For The Installation & Maintenance Of Continuous Emission Monitoring Systems (CEMS) For Industrial Premises / Facilities

# Chapter 3 ▶ Continuous Emission Monitoring System (CEMS)

A continuous emission monitoring systems (CEMS) is an integrated system that demonstrates source compliance by collecting samples directly from the duct or stack discharging pollutants to the atmosphere. A CEMS consists of all the equipment necessary for the determination of a gas or particulate matter concentration or emission rate. This includes three (3) basic components:

- The sampling and conditioning system
- The gas analyzer and/or monitor; and
- Data acquisition & handling system (DAS/ DHAS) and controller system

This chapter will further elaborate on the CEMS and its components as described above.

## 3.1 Sampling Systems

CEMS can be divided into two (2) major categories based on sampling method which are extractive and in-situ. Extractive CEMS captures a sample from the duct or stack, condition the sample by removing impurities and water, and transport the sample to the analyzer in a remote, environmentally protected area (**Figure 3.1**). In-situ CEMS typically have monitors and/or analyzers located directly in the stack or duct (**Figure 3.2**).

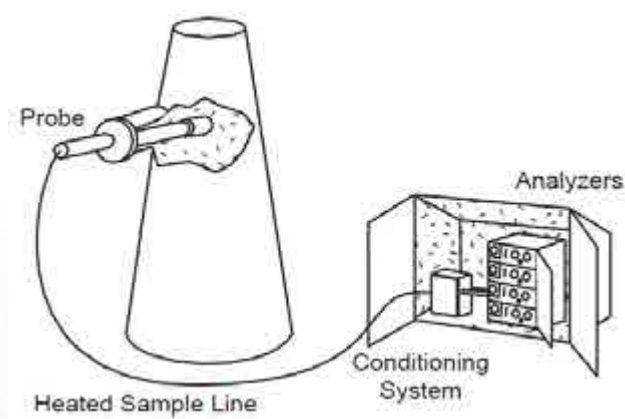

**Figure 3.1 Example of Extractive CEMS (source : USEPA<sup>1</sup>)**

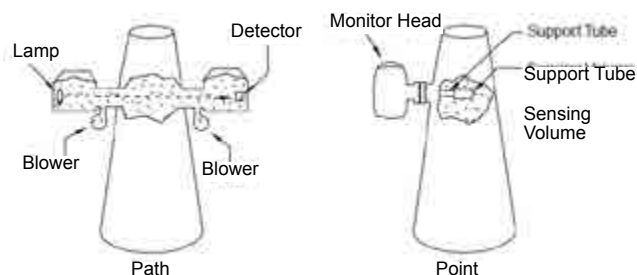

**Figure 3.2 Example of In Situ CEMS (source : USEPA<sup>1</sup>)**

### 3.1.1 Extractive CEMS

3.1.1.1 Extractive CEMS comprises of analyzer and additional devices (such as conditioning system) to obtain a measurement result.

3.1.1.2 There are several types of extractive sampling system which are:

- Simple heated lines coupled with heated analyzers that measure gases in a hot, wet form.
- Heated lines and chiller-driers, delivering the sampled gases to the analyzer in cooled, dry form.
- Heated lines and permeation-driers, delivering the sampled gases to the analyzer in cooled, dry form.
- Dilution systems, although these are rarely and not allowed to be used in Malaysia.
- The stack-mounted probe is coupled directly to a permeation drier, which then passes the cooled, dry sample gas via an unheated line to an analyzer.
- There may be a NO<sub>x</sub> converter to convert NO<sub>2</sub> to NO in cases where the operator needs to monitor total NO<sub>x</sub> using an analyzer which measures NO alone.

3.1.1.3 There are also many variations of these basic forms and as analyzers are typically designed for use with specific types of sampling system. Certified CEMS analyzer will also state and certify the type of sampling system.

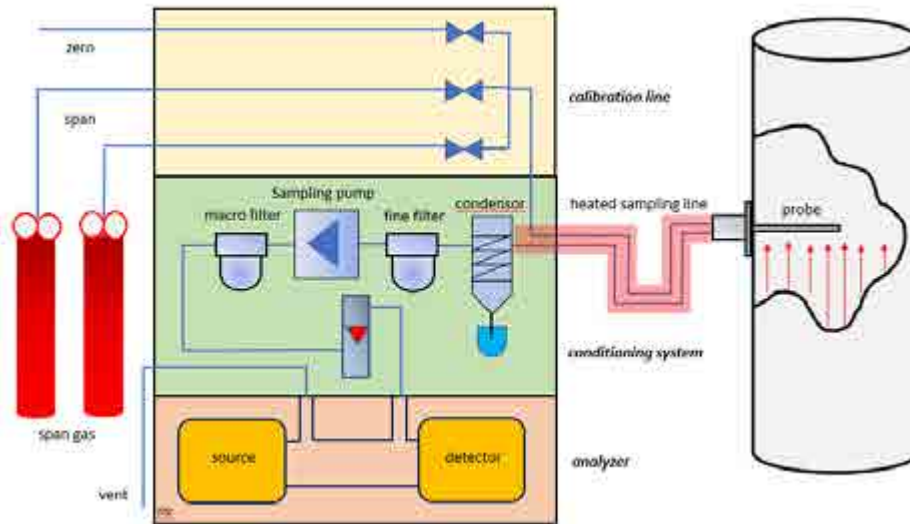

**Figure 3.3: Basic Extractive CEM System**

3.1.1.4 Depending on the type of system, extractive CEMS sampling system, conditioning equipment can include sampling probe/port, sampling transfer line, line heaters, calibration gases, a pump, a filter, a condenser or dryer or chillers. Figure 3.3 show a basic extractive CEMS.

**3.1.2 In-Situ**

In-situ CEMS is a system which the analyzer is physically located on the stack or duct. The pollutant is measured in-situ as it flows through a sampling location placed in the stack or duct. Two (2) types of in-situ measurements are as follows:

- a) Point (in-stack) – measurement takes place at the single point in the stack, as do simple extractive system probes.
- b) Path (cross-stack) – measurements are taken across a given path in the emission stream. In-situ path measurement is taken by transmitter sending a signal across the stack and reflecting it back to a detector near the source of signal. Even there are two (2) basic types of in-situ path which are single pass and double pass, only double pass in-situ path CEMS are accepted by DOE. **Figure 3.4** illustrates the typical type of CEMS In-situ Point and In-situ Path.

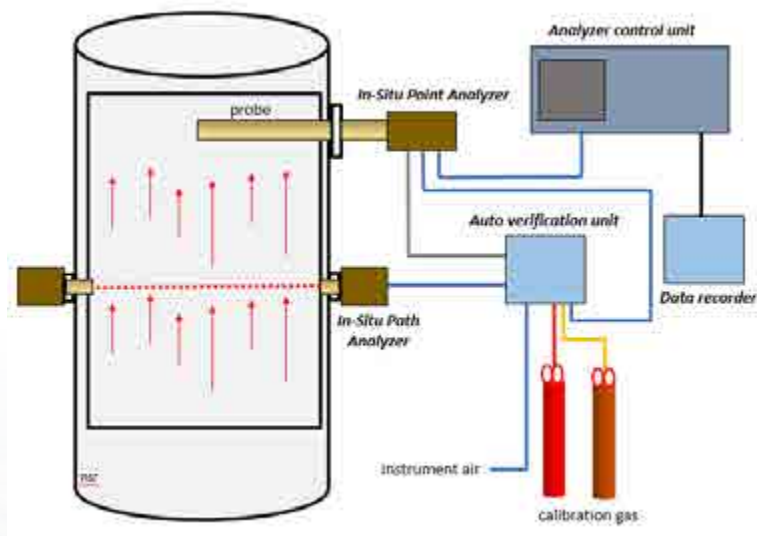

**Figure 3.4 - Typical In-situ Path and In-situ Point CEM System**

**VOLUME 1: Guidelines For The Installation & Maintenance Of Continuous Emission Monitoring Systems (CEMS) For Industrial Premises / Facilities**

### 3.2 Selection of CEM Sampling System

Figure 3.5 summarizes the CEM sampling system. Applicant shall justify to DOE which are the best or suitable CEM sampling systems to be installed, operated and maintained based on their application. Table 3.1 summarizes the comparison of features between extractive and in-situ system.

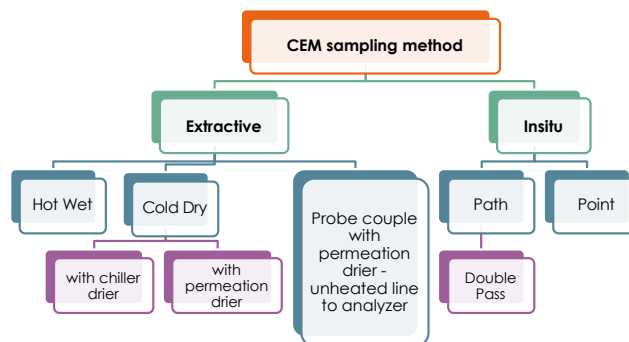

Figure 3.5 – Summary of the CEM Sampling Method Recognized by DOE

Table 3.1 - Comparison of features between extractive and in-situ

Features of Extractive System	Features of In-situ System	
	Path	Point
Can sample from point of average concentration	Linearly average concentration	Can sample from point of average concentration
Can time-shares analyzer	Cannot time shares analyzer	
Analyzer readily located in environmentally controlled shelter, rooms	Analyzer subject to ambient environmentally conditions. Installation of protective casing or shelter is highly recommended.	
Have large number of maintainable system components	Have fewer number of maintainable system components	
System components may be relatively easy to repair (e.g.: pump, valve)	System components may be relatively difficult to repair (e.g.: optics, electronic)	
Use cylinder gas for calibration	May use internal gas cell or internal calibration filter for calibration	
Can easily audit with cylinder gas	Cylinder gas audit may require aspecial attachment	Can easily audit with cylinder gas
Do not require temperature compensation	Require temperature compensation	
Sample gas filtered, conditioned to standard, temperature, pressure	High stack temperature and moisture, high particulate matter, sticky particulate matter may affect performance	
May alter sample if any extractive component failure	Do not alter sample	
Response time dependent on sample line length	Response time dependent on analyzer response, not sampling	
System problems readily solved on site	System probe may be difficult to solve on site (e.g.: electro optical problems at stack height)	
Maintenance may not require special training	Maintenance may require higher levels of training	
Inspection maintenance required 2-3 times per week, minimum (depending on maintenance interval specified)	Inspection/maintenance less than those required for extractive systems	



### 3.3 CEM Analyzers

3.3.1 The heart of any CEMS either extractive or in-situ is the analyzer. The analyzer will perform the job of measurement of pollutant through the monitoring technique. The monitoring techniques vary from chemical methods using simple electrochemical cells to advanced electro-optical techniques such as Fourier Transform Infrared Spectroscopy.

3.3.2 **Table 3.2** gives summary of the typical monitoring techniques that are used in CEMS. Typically, the plant operator aware of what pollutant requires sampling, but will need guidance on the monitoring technique and analyzer to be used. **Table 3.3** has been structured to enable the plant operator or CEMS consultant to determine an appropriate and a suitable monitoring technique for the respective stack.

3.3.3 Facility and stack that emit particulate matter, shall select CEM analyzer by considering type of air pollution control system installed at the facility.

3.3.4 The selection of CEM analyzer must consider both regulatory specifications and performance characteristics. Physical characteristics of the gas stream that need to be considered in CEM analyzer selection are inclusive of:

- a) Moisture content -
  - Often determines the suitable detection principle, system configuration or design. This is highly applicable for wet particulate matter monitoring.
  - In order to propose either in-situ or extractive types of particulate type

analyzer to be installed by plant operator, determination of water vapour concentration in the flue gas emitted to atmosphere from ducts and stacks can be through process data provided by engineering design or actual process data or to be carried out by plant operator by implementing procedures stated in BS EN 14790:2017 or any other method approved by the Director General of DOE.

- The CEMS manufacturer will then give a recommendation on which methods suitable to be used depending on field test data for moisture level that has been tested for the analyzers to be installed onsite.
- b) Particulate content –
    - Determine the design of filtering prior to gas analysis and to identify the suitable PM analyzer configuration.
  - c) Temperature –
    - Determine the materials of construction.
  - d) Pressure –
    - Determine connection/ mounting the system onto the duct and system used to obtain the sample.
  - e) Presence of corrosive components such as HCl.
  - f) Type and proximity to abatement equipment.
  - g) Concentration of component to be measured.

Table 3.2 – Typical analytical techniques used in CEM System

No	Monitoring technique	Sampling Type	Pollutant measured	Note
1	<b>Absorption Spectroscopy - Infrared (IR) or Ultraviolet (UV)</b>			
	Nondispersive Infrared (NDIR)	Extractive	CO, CO <sub>2</sub> , SO <sub>2</sub> , NO <sub>x</sub> , etc.	Multiple gases can be monitored, generally no more than 2-5.
	Nondispersive Ultraviolet (NDUV) – Differential Absorption	Extractive	SO <sub>2</sub> , NO <sub>2</sub> , NH <sub>3</sub> , Cl <sub>2</sub> etc.	Multiple gases can be monitored, generally no more than 2-5.
	Differential optical absorption spectroscopy (DOAS)	In-situ	CO, CO <sub>2</sub> , SO <sub>2</sub> , HCl, HF, NO, NO <sub>2</sub> , NH <sub>3</sub> , VOCs, H <sub>2</sub> O	Multiple gases can be monitored, typically more than 5 and NO <sub>2</sub> is measured directly. Additional gases can be added at relatively low cost.
	IR Gas filter correlation (GFC)	Extractive / In-situ	CO, CO <sub>2</sub> , NO <sub>x</sub> , SO <sub>2</sub> , N <sub>2</sub> O	Multiple gases can be monitored, generally no more than 2-5.
	Fourier transform infrared (FTIR)	Extractive / In-situ Path	CO, CO <sub>2</sub> , SO <sub>2</sub> , NO <sub>x</sub> , HCl, HF etc.	Multiple gases can be monitored, typically more than 5.
	Photo acoustic (PAS)	Extractive	CO, CO <sub>2</sub> , SO <sub>2</sub> , HCl, HF, NO, NO <sub>2</sub> , NH <sub>3</sub> , VOCs, H <sub>2</sub> O	Can measure virtually any gas that absorbs IR. Detailed analysis of other compounds that may be present other than target gases required.
2	<b>Luminescence methods</b>			
	Fluorescence	Extractive	SO <sub>2</sub> , H <sub>2</sub> Sa, TRSa	a can also be measured but not simultaneously.
	Chemiluminescence	Extractive	NO, NO <sub>x</sub> , NO <sub>2</sub> b	b NO <sub>2</sub> calculated (NO <sub>x</sub> – NO)
3	<b>Electro analytical methods</b>			
	Electrochemical O <sub>2</sub>	Extractive	O <sub>2</sub>	
	Para magnetism	Extractive	O <sub>2</sub>	
	Zirconia oxide cell	In-situ	O <sub>2</sub>	Widely used, maximum temperature generally 500°C.
4	<b>Other methods</b>			
	Flame Ionization Detector (FID)	Extractive	Total HC	Requires hydrogen carrier gas.
	Tunable Laser Diode (TLD)	In-situ Path	HCl, HF, NH <sub>3</sub> , CH <sub>4</sub> , CO, CO <sub>2</sub> , H <sub>2</sub> O	Cost effective for single component applications.
5	<b>Particulate Matter</b>			
	Extinction	In-situ Path	PM, Opacity	High moisture flue gas may affect the accuracy of Opacity and PM reading and indicates unrepresentative PM emission.
	Dynamic Opacity	In-situ Path	PM, Opacity	
	Light Scatter	In-situ Path	PM	Forward, Side or Backward Light Scattered.
		Extractive	PM	For wet monitoring.
	Probe Electrification	In-situ Point	PM	e.g.: Tribo-electric probe
Beta Absorption	Extractive	PM		

**Table 3.3 – Substance to monitor with the applicable monitoring technique**

Substance	Type of sampling CEMS	Monitoring technique	Further information
Carbon dioxide; CO <sub>2</sub>	In-situ	NDIR	CO is a positive cross interference. Methane also interferes.
		DOAS	Simultaneous monitoring of CO <sub>2</sub> along with many other pollutants. Range up to 100%, LOD approx. 0.1% by volume.
	Extractive	NDIR analyzer	Interference from CO, water, methane and ethane.
		FTIR analyzer	Simultaneous monitoring of CO <sub>2</sub> along with many other pollutants. Faster response than NDIR. Typical range 0 to 35%.
Carbon Monoxide; CO	In-situ	NDIR	Measurement of CO and CO <sub>2</sub> . CO <sub>2</sub> is positive cross interference. Methane also interferes, primarily with CO <sub>2</sub> . LOD <3 mg/m <sup>3</sup> .
		DOAS	Measurement of CO and CO <sub>2</sub> . Typical range up to 10,000 mg/m <sup>3</sup> .
	Extractive	NDIR	Interference from water, methane and ethane.
		Electrochemical cell	Requires appropriate conditioning and purging with clean air for sensor recovery.
		FTIR	Measurement of CO and CO <sub>2</sub> . Wide range typically up to 10,000 mg/m <sup>3</sup> ; short response times; low LODs. Reduced interferences compared to NDIR.
Hydrogen Chloride; HCl	In-situ	DOAS	Measures HCl, specifically, rather than total chlorides. Simultaneous monitoring of HCl along with many other pollutants. Measures gas-phase HCl only. Range up to 5000 mg/m <sup>3</sup> , LOD <1 mg/m <sup>3</sup> . Not suitable for the measurement of chlorides.
		Tunable diode laser	The measurement targeting specific absorption lines in the near-infrared spectrum, providing high selectivity, fast response, and low detection limits with minimal cross-interference, ensuring reliable compliance monitoring in stack emissions.
		NDIR analyzer	NDIR detects gas concentration by measuring HCl's specific infrared absorption wavelength. The analyzer uses an IR source, gas cell, and detector to quantify absorption intensity, providing continuous, selective, and reliable monitoring of HCl emissions in flue gas.
	Extractive	NDIR analyzer	Interference from particulates, H <sub>2</sub> O, CO, CO <sub>2</sub> and any other IR-absorbing components.
		FTIR	Measures HCl, specifically, rather than total chlorides Simultaneous monitoring of HCl along with many other pollutants. Faster response and fewer interferences than NDIR. Typical range up to 1000 mg/m <sup>3</sup> . Measures gas phase HCl only.
		Ion mobility spectrometry	LOD down to ppb levels.

Substance	Type of sampling CEMS	Monitoring technique	Further information
Hydrogen Chloride; HCl	Extractive	Continuous-flow analyzers, based on IC, ISE etc.	Simultaneous monitoring of chloride is expressed as HCl along with many other halides. Measures gas phase only. Not specific to HCl (also responds to chlorides). Interference from particulates, H <sub>2</sub> O, CO <sub>2</sub> , Cl <sub>2</sub> , SO <sub>2</sub> , SO <sub>3</sub> , NO <sub>2</sub> and NH <sub>2</sub> . Slow response time require consumable reagents.
Hydrogen Fluoride; HF	In-situ	DOAS	Can measure gas-phase HF. Does not measure fluoride salts. For HF, range is 0-1,000 mg/m <sup>3</sup> , LOD 0.2 mg/m <sup>3</sup>
		NDIR analyzer	Can measure gas-phase HF. Does not measure fluoride salts. Interference from particulates, H <sub>2</sub> O, CO <sub>2</sub> and any other IR-absorbing components.
	Extractive	FTIR	Applicable to gas-phase HF. Reduced interference compared to NDIR and faster response. Does not fluoride salts
		IMS	Can measure gas-phase HF. Suitable for ppb levels.
		TDL	Can measure gas-phase HF.
		Continuous-flow analyzers, based on IC, ISE etc.	Instruments available for measuring gas-phase HF. Measures halides absorbed into collection solution. Interference from particulates, CO <sub>2</sub> , SO <sub>2</sub> , SO <sub>3</sub> , NO <sub>2</sub> and NH <sub>3</sub> . Require consumable reagents.
Nitrogen Monoxide; NO and Nitrogen Dioxide; NO <sub>2</sub>	In-situ	NDUV	Measurement of NO and NO <sub>2</sub> . The principal interference is from SO <sub>2</sub> .
		DOAS	Measurement of NO, NO <sub>2</sub> . Typical range up to 2,000 mg/m <sup>3</sup> , LOD <1 mg/m <sup>3</sup> .
		NDIR	Measurement of NO and NO <sub>2</sub> . Wide range (typically NO to 5,000 mg/m <sup>3</sup> , NO <sub>2</sub> to 5,000 mg/m <sup>3</sup> ). Main interference from particulates and H <sub>2</sub> O, which can be reduced by precise selection of wavelength. Not suitable for high-moisture gases
	Extractive	NDUV	As above for in-situ CEMS
		NDIR	As above for in-situ CEMS. Main interference from particulates and H <sub>2</sub> O, which can be removed by conditioning.
		Chemiluminescence	Measurement of NO and NO <sub>2</sub> . Very low LOD (typically 0.1 ppm); wide range (typically 0-10,000 ppm); short response (a few seconds). The principal interference is from CO <sub>2</sub> , H <sub>2</sub> O and NH <sub>3</sub> .
		Electrochemical	Measurement of NO and NO <sub>2</sub> typically up to 3,000 ppm and 500 ppm, respectively. Require appropriate conditioning and purging with clean air for sensor recovery.
		NDIR	Measurement of N <sub>2</sub> O. Steps required to reduce potential interference effects of CO, CO <sub>2</sub> and moisture.
		FTIR analyzer	Simultaneous monitoring with many other pollutants. Faster response and less interference than NDIR. Measurement of NO, NO <sub>2</sub> and N <sub>2</sub> O.



Substance	Type of sampling CEMS	Monitoring technique	Further information
Oxygen; O <sub>2</sub>	In-situ	Zirconium oxide film	Main interferences: hydrocarbons, CO.
		Paramagnetic analyzer	Range 0-100% with a typical resolution of 0.1%. Interference from high concentrations of NO <sub>2</sub> , NO and certain hydrocarbons.
	Extractive	Electrochemical cell	Electrochemical cells can also be mounted in the gas stream for an in-situ CEMS measurement. Interference from SO <sub>2</sub> , NO <sub>x</sub> and acid gases. Requires appropriate conditioning and purging with clean air for sensor recovery.
		Tunable diode laser	A TDL enables precise O <sub>2</sub> measurement by targeting specific absorption lines in the near-infrared spectrum. It provides fast response, high selectivity, and stable performance, minimizing interference from other gases and ensuring reliable monitoring in flue gas applications.
		Zirconium oxygen gas analyzer	Measure oxygen using electrochemical potential differences generated from oxygen ion conductivity at high temperatures.
Particulate Matter; PM	In-situ	Optical Extinction or Scintillation (Opacity meter or Transmissometer)	Opacity or smoke density measurements. Laser opacimeters have LOD down to 1 mg/m <sup>3</sup> .
			Does not measure mass of particulates directly.
			Concentration calibration factor dependent on particle size, composition, shape, colour and refractive index.
			Gives a measure of particulate concentration after calibration with gravimetric SRM. Typical ranges from about 10 to 2000 mg/m <sup>3</sup> . Not suitable for low concentration emissions.
		Tribo-electric probe (probe electrification)	Stack with high moisture may affect the accuracy of PM reading and indicate unrepresentativeness. This type of emission typically occurs at biomass boiler which uses fuel with high moisture content.
			It can be used simply as an alarm indicator or as quantitative monitor.
			Claimed to be suitable for low particulate concentrations (LOD less than 1 mg/m <sup>3</sup> ).
		Light scattering (Forward, Side or Backward Light Scattered)	Tribo-electric response dependent on particle size, composition and moisture.
			Gives a measure of particulate concentration after calibration against SRM.
			Reported to be suitable for low particulate concentrations (LOD down to 1 mg/m <sup>3</sup> ).
Gives a measure of particulate concentration, but only after calibration with SRM.			

Substance	Type of sampling CEMS	Monitoring technique	Further information
Particulate Matter; PM	Extractive	Beta-attenuation monitor	Can be calibrated to give particulate concentration in mg/m <sup>3</sup> directly.
			Gives successive average readings over set sampling periods.
			Absorption coefficient is independent of particulate composition.
			The typical range about 2 to 2,000 mg/m <sup>3</sup> depending on sampling rate, frequency and integrating time.
		Extractive light-scattering	Suitable for low particulate concentrations.
			Extractive parts of the system may retain particulates. Manufacturer's data: range 0-1000 mg/m <sup>3</sup> ; LOD 0.02 mg/m <sup>3</sup> ; reproducibility 0.5% FSD.
Sulphur dioxide; SO <sub>2</sub>	In-situ	NDUV	Low limit of detection.
			Wide linear response range.
			Short response times.
			Monitoring by NDUV is the most encountered CEMs technique.
		DOAS	The principal interference is from H <sub>2</sub> O and NO <sub>2</sub> . Simultaneous monitoring of SO <sub>2</sub> along with many other pollutants. SO <sub>2</sub> range up to 2000 mg/m <sup>3</sup> , LOD <1 mg/m <sup>3</sup> .
			NDIR
	Extractive	UV-fluorescence and UV-absorption IR-absorption	
			Particulates and H <sub>2</sub> O can be removed by conditioning, leaving as the principal
			Interference CO, CO <sub>2</sub> , NO, NO <sub>2</sub> , SO <sub>3</sub> , unsaturated hydrocarbons, aromatic amines and nitro-compounds
		Electrochemical	Typical range up to 5000 ppm. Can also be installed in situ in duct.
			Requires periodic purging with pure air for the sensor to recover.
			Removal of particulates and moisture is necessary to stop the condensation and dissociation of salts.
FTIR	Simultaneous monitoring of many pollutants. Faster response and fewer interferences than NDIR.		



Substance	Type of sampling CEMS	Monitoring technique	Further information
VOCs (total)	Extractive	FID analyzer	Validated at waste incinerators.
			High specificity to VOCs.
			Developed for incinerators.
			Different response factors for each VOC species.
			Suitable for low ranges of VOC concentrations (0-20 mg/m <sup>3</sup> ). Interference from oxygen (reduced by mixed H <sub>2</sub> /He fuel).
			Extensively validated for solvent processes.
			High specificity to VOCs. Different response factors for each VOC species.
VOCs (specified)	In-situ	DOAS	Can measure certain specific organic compounds, e.g. benzene, toluene and xylene.
			Benzene typical range 0-1,000 mg/m <sup>3</sup> , LOD 1 mg/m <sup>3</sup> ; toluene typical range up to 1,000 mg/m <sup>3</sup> , LOD 0.5 mg/m <sup>3</sup> ; xylene typical range up to 1,000 mg/m <sup>3</sup> , LOD 1 mg/m <sup>3</sup>
	Extractive	Continuously-cycling GC with appropriate detector (FID, ECD)	Can measure virtually any individual organic compounds, many simultaneously.
			Not truly continuous, but successive measurements in cycles of about 30 minutes. LOD typically 1 ppm.
		FTIR analyzer	Can measure many individual organic compounds simultaneously, with better specificity, LOD (at ppb level) and better response than NDIR.
			Can measure many individual organic compounds, but only one at a time. Instruments must be set up specifically for determination and interest. Interferences from H <sub>2</sub> O and other species with overlapping spectrum.
Water vapour (moisture)	In-situ	NDIR	In widespread use. Interference from other IR absorbing species, e.g. CO, CO <sub>2</sub> hydrocarbons.
		DOAS	Simultaneous monitoring of H <sub>2</sub> O and other pollutants. Typical range 0-30%, LOD approx. 0.1% volume.
	Extractive	NDIR analyzer	Interference from CO, CO <sub>2</sub> , hydrocarbons.
		FTIR analyzer	Simultaneous monitoring of H <sub>2</sub> O and other species.
			Faster response than NDIR. Typical range 0 to 35%.
		Paramagnetic analyzers	Range 0-100%, typical resolution 0.1%.
			H <sub>2</sub> O calculated from the difference between two analyzers, one measuring O <sub>2</sub> wet and other dry.
			Not a direct measurement of moisture. Interferences from high concentration of NO <sub>2</sub> , NO and hydrocarbons.

### 3.4 Data Acquisition Handling System (DAHS/DAS)

3.4.1 A CEMS is not complete without incorporating a subsystem that records the data produced by the monitors/analyzers. The data acquisition handling system (DAHS/DAS) provides this record of emission measurements. Activities such as reviewing data and log, checking calibration values, responding to excess emissions problems and generating reports are all performed within the DAHS. **Figure 3.6** gives summary of CEMS control and data acquisition and handling function.

3.4.2 The essential function of the DAHS is to display, record, and report. The features of DAHS shall be considered include the following features:

- a) Default screen - Half hour and daily summaries – to show the compliance with ELV.
- b) Showing real-time or/and averaged data (1 minute, 30 minutes and daily average).
- c) Alarm screen - showing the alarm (calibration failure, excess emission and fault alarm) occurring over a specified period.
- d) Calibration report – showing calibration gas and calibration kits certified values, instrument response, drift and percentage drift.
- e) The system shall provide a continually updated display of parameters measured and corrected by the monitoring system. The display should provide easily readable formats in one screen or several screen.
- f) The system shall have the capability to display raw, real time, averaged, normalized, calibrated and historical data.
- g) To include calibrated data which derived from the application of calibration function obtained from the QAL2-CVT.

h) The DAHS calculation steps in sequence shall be documented and made available for review by the DOE. The calculations shall be in order from raw data through to reported values:

- Collection of raw data, as measured and without correction to STP and Oxygen or Carbon Dioxide reference. This shall be un-editable.
  - Calculation of corrected values (to STP dry).
  - Correction of STP dry values to reference Oxygen or Carbon Dioxide (whichever applicable and if required).
  - Determination of averages, i.e. 1 minutes (opacity), 30 minutes, hourly and daily.
- i) It shall be possible to display historical data in trend plots. Trend plot should be from minutes, half hours, daily, monthly and yearly.
  - j) The system displays information shall be able to be printed.
  - k) Calibration drift data shall be presented in quality control charts, updated automatically after each calibration check.
  - l) If possible, colour coded shall be used to block set of data, highlight suspect data, highlight alarm, and in general provide visual interest and alert to operator, user or auditor.
  - m) If possible, graphic shall be used to visualize the stack or outline of the CEMS condition.

3.4.3 Verification of data during installation and operation is critical to ensure representative data. Data collected shall be checked through from the raw data which taken directly from the analyzer to the final data. These data shall be then used to check the outputs from the DAHS and compare.

Note: Final data is defined as a corrected, normalized and calibrated data

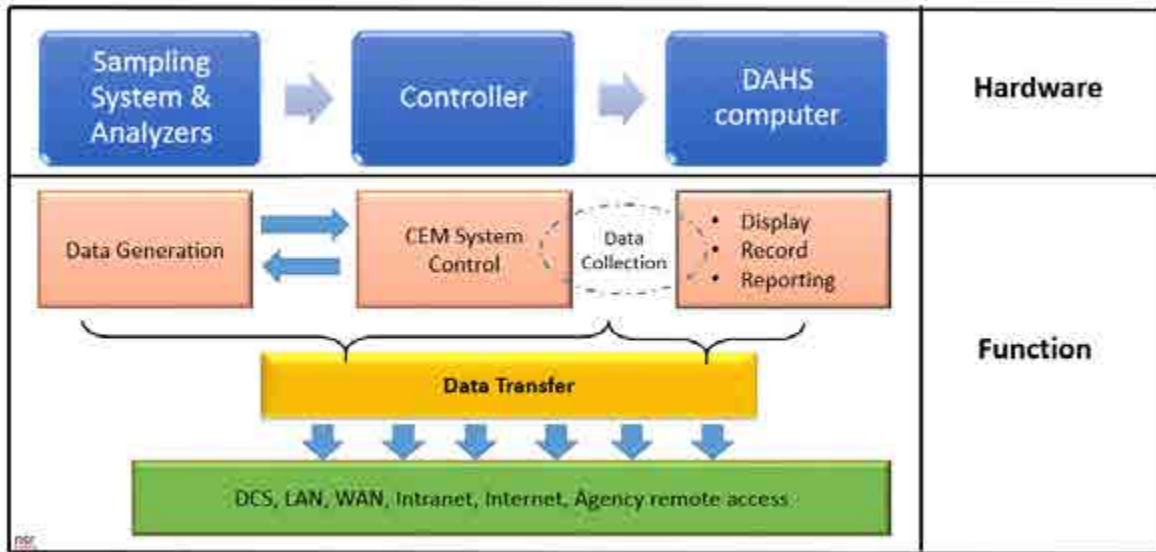

**Figure 3.6–CEM System control and DAHS functions**

### 3.5 Data Availability

#### Data Interface System (CEMS-DIS)

- 3.5.1 The CEMS must be designed to transmit data to the DOE system for CEMS and the protocol used to transmit data via internet connectivity (e.g. a broadband other telecommunications system) shall follow a data telemetry access protocol. This shall be done by preparing an intermediary component called CEMS Data Interfacing System (CEM-DIS) to store CEMS data from DAS and communicate with centralized DOE server for CEMS data transferring purposes.
- 3.5.2 Volume II: Guideline for the Continuous Emission Monitoring System – Data Interface System (CEMS-DIS) for Industrial premises / Facilities is the guideline for the developing and implementing CEMS-DIS with standard data format and units of the standards for the transmission of data to the DOE system for CEMS.
- 3.5.3 All the transferred data can be viewed and accessed by plant operator itself and DOE through DOE system for CEMS developed by DOE.



# Chapter 4 ►

## CEMS Requirements

Installation of CEMS at plant operator’s facility requires application to DOE beforehand and must be installed by a registered CEMS consultant. CEMS proposed by the DOE registered consultant to be installed and operate shall follow DOE requirements which involve design specification, installation requirement and initial performance audit procedures.

### 4.1 Design Specifications

4.1.1 Each analyzer and CEMS component or equipment installed as a CEMS for compliance monitoring and reporting shall comply one or more of the international standards as below:

- a) United Kingdom Monitoring Certification Scheme (MCERTS) – EN15267-3 & EN14181 QAL1 or
- b) German Technical Inspection and Monitoring Union (TUV) QAL1-EN15267-3 & EN14181 QAL 1 or
- c) Malaysian Standard MS 2564 - Performance Criteria and Test Procedure For CEMS.

CEMS consultants shall ensure TUV or MCERT certificate is still valid prior CEMS supply and installation.

4.1.2 Existing CEMS installation with a discontinued MCERT/TUV certification due to version or model upgrading, shall seek prior consent from DOE to keep using the system provided the CEMS is still able to meet the requirements of QAL2, QAL3 and AST.

4.1.3 For PM CEMS (or gas CEMS without oxygen measurement), peripheral devices such as oxygen (if applicable) shall be certified by MCERT or TUV and same applied to the SRM that uses instrumental techniques.

4.1.4 For measurement of moisture used for compensation in CEMS hot-wet system, it is required to install moisture analyzer.

4.1.5 CEMS shall be able to provide valid data average as mentioned in sub chapter 2.3 of this guideline.

4.1.6 The emission value of CEMS shall be calculated in term of mass of pollutants per volume of the waste gases (expressed as mg/m<sup>3</sup>), assuming standard conditions for temperature and pressure (STP) for dry gas (volume at 273K, 101.3 kPa).

4.1.7 The emission value of CEMS shall be normalized to reference gas (if applicable) as mentioned in Second Schedule and Third Schedule of CAR 2014 or any reference value specified by DOE.

4.1.8 There is a difference between the certification range and the measurement range of the CEMS. The definitions are as follows:

Type of range	Definition
Measuring range	The set of values that the CEMS can measure, from the lower detection limit (i.e. near zero) to a set upper limit
Certification range	The smallest range over the CEMS can meet the MCERT/TUV performance standards. Some CEM may have more than one certification range and the lower the certified range, the better performance of the CEM is likely to be.

4.1.9 The CEMS data recorder output range must include zero and high-level value. The high-level value of measuring range must be between 2.5 times the ELV.

4.1.10 In selecting a suitable CEMS, the maximum concentration value of the lowest certified range shall not be more than 2.5 times ELV for fuel-burning equipment and other processes and shall not be more than 1.5 times ELVs for waste incinerator.

4.1.11 **Table 4.1 & 4.2** below shows some examples of typical daily average ELVs and the corresponding certified ranges for CEMS installed at gas turbine and waste incineration plant.

**Table 4.1 – Certified ranges for CEMS installed at gas turbine using hydrocarbon gas fuel**

Parameters	Daily average ELV (mg/m <sub>3</sub> )	Certified range (mg/m <sub>3</sub> )
NOx	150	0 – 375
CO	100	0 – 250

**Table 4.2 – Certified ranges for CEMS installed at waste incineration plant**

Parameters	Daily average ELV (mg/m <sup>3</sup> )	Certified range (mg/m <sup>3</sup> )
NOx	200	0 – 300
SO <sub>2</sub>	50	0 – 75
CO	50	0 – 75
TPM	100	0 – 150
HCl	40	0 – 60
HF	1	Any available

Note: ELVs are based on CAR, 2014

4.1.12 CEMS shall also be able to measure instantaneous values over the ranges which are to be expected during all operating conditions. If it is necessary to use more than one range setting of the CEMS to achieve this requirement, the CEMS should be verified for monitoring supplementary higher certified range.

4.1.13 CEMS response time must be less than 200 seconds, and it is also referred to as 90% time.

Note 1: In situ CEMS (analyzer response time)  
Extractive CEMS (lag time + analyzer response time)

Note 2: Lag time of the gas samples in the lines, i.e. the time between sampling and analysis. The transfer times in the CEMS and SRM lines are calculated considering the lengths of the lines, their geometry and the incoming flow.

4.1.14 Measurement uncertainty - the CEMS shall meet the measurement uncertainty requirements as specified in **Table 4.3** below or other equivalent requirements acceptable to the DOE.

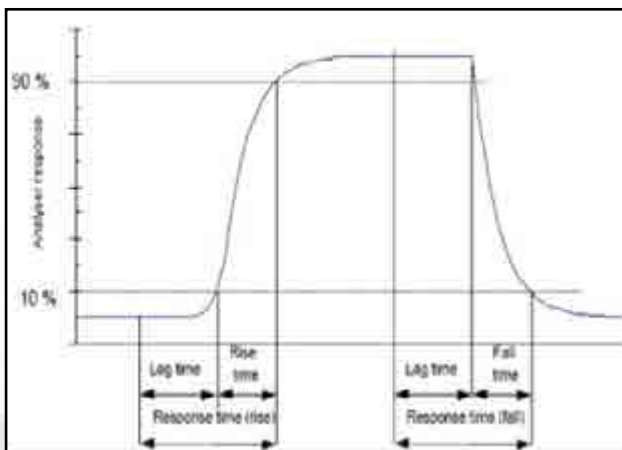

**Table 4.3 – Requirement on the measurement of uncertainty of CEMS**

Emission Parameter	Values of the 95% confidence intervals of a single measured
Carbon Monoxide	10%
Sulphur Dioxide	20%
Nitrogen oxides / Nitrogen Dioxide	20%
Dust/ Total Dust	30%
Total Organic Carbon	30%
Hydrogen Chloride	40%
Hydrogen Fluoride	40%

4.1.15 Functionality of CEMS:

- a) All CEMS must have a provision that allows either plant operators, CEMS consultant or CEMS tester to perform zero check, span check and linearity test once CEMS has been installed.
- b) Extractive CEMS must have the means for leak checks, such as the provisions for applying test gases at the sampling probe to check and to prove the integrity of the entire sampling system. This calibration line shall be made available, and the entire sampling system checking is compulsory to be conducted during functional test.
- c) Such provision could also be used to test the response time of the entire system.
- d) Surrogate reference materials are required for performing zero and span check on particulate monitoring CEMS and these shall be assessed as part of the MCERTS/TUV testing, for their validity in providing an appropriate QAL3 check. However, it is permissible to use surrogates and alternative devices such as filters or electronic simulations for particulate matter, if these have been validated during the MCERTS/TUV testing for QAL1.

4.1.16 The CEMS must be designed to be able to perform zero and span check:

- a) Zero and span checks shall be performed using reference material such as calibration gas, or surrogates (such as filter or field current).
- b) Calibration gases must have a validity in the certificate of analysis and the gases concentrations are corrected to Standard Temperature Pressure (STP), if expressed in mg/m<sup>3</sup>.

- c) Any surrogates including filter, field current, calibration block etc. must be certified QAL1 and to be dedicated reference materials for the installed CEMS.
- d) Zero and span level for reference material shall follow below:
  - i. For Gas; Zero level (0-20%) of span value and span level (80-100%) of 2.5 times daily ELV. Alternatively, it is good practice to use a span gas that has concentration of approximately 80% of the operating range that includes the relevant pollutant's emission values. It shall be noted that the higher the concentration, the more sensitive the span check will be to changes.
  - ii. For Opacity: low level (0-10%) and span level of (40-60%).
  - iii. For PM: low level (0-10%) and span level of (50-100%) of the full-scale measurement range (max. mg/m<sup>3</sup>).
- e) Even though there are certified CEMS with zero and span check either automatic or manual, DOE preferred CEMS with automatic zero and span check since this test can be conducted without additional work or personnel and will not incur any additional operation cost to the plant operator. This will ensure the checks are regularly conducted as required.

4.1.17 For particulate matter CEMS, it is essential that the device be calibrated on the process being measured. A gravimetric reference method (such as EN13284-1/USEPA Method 5/MS 1596) shall be used to correlate the output of the device with the obtained results (initial setting).

4.1.18 Particulate matter is measured using a surrogate, such as light and has a variable response to different particle physical characteristics. Hence, calibration must be undertaken typically on an annual basis. Calibration on an annual basis or shorter interval in accordance with manufacturer's recommendation. The calibration will be based on gravimetric weight measurement.

4.1.19 Extractive CEMS comprises of analyzer and sampling system which has been tested and certified. There are many variations of sampling systems and as analyzers are

typically designed for use with specific types of sampling system, testing and subsequent approvals will certify a CEMS with a stated type of sampling system. Some common sampling systems are:

- a) Simple heated lines coupled to heated analyzers that measure gases in a hot, wet form.
- b) Heated lines and chiller-dryers, delivering the sampled gases to the analyzer in cooled, dry form.
- c) Heated lines and permeation-dryer, delivering the sampled gases to the analyzer in a dry form.
- d) Dilution systems (not allowed to be used in Malaysia).
- e) The stack-mounted probe coupled directly to a chiller-dryer or permeation dryer, which passes the cooled/dry sample gas, via an unheated line, to an analyzer.
- f) There may be NO<sub>x</sub> converters to convert NO<sub>2</sub> to NO in cases where the operator needs to monitor total NO<sub>x</sub> using an analyzer which measures NO alone. NO<sub>x</sub> conversion by using conversion factor or any means other than specified in the certificate is not allowed.

4.1.20 For extractive CEMS, use the sampling system as specified in the certificate. It shall consist of components below:

- a) Sample probe – shall be made by the approved material and suits with flue gas characteristic and temperature. It must be of sufficient length to ensure that a representative sample is drawn, and the probe insertion meets measurement point criteria specified in item 4.2.7 of this guideline.
- b) Sample line from the probe to the conditioning system/sample pump, shall be made by approved material that does not absorb or otherwise alter the sample gas. The temperature of the sample line (heated sampling line) must be maintained at sufficiently high level (>180°C or above sample dew point) to prevent condensation before the sample conditioning component/ analyzer
- c) Conditioning equipment – for dry basis measurement, a condenser, dryer or other suitable device is required to remove moisture continuously from the sample gas.

- d) Particulate filter (in stack or out of stack filter), the filter must be made of material that is nonreactive to the gas being sampled.
- e) Calibration gas manifold system – shall be prepared to allow introduction of calibration gases. Plant operators shall ensure the availability and readiness of this system should prompt calibration tests required during DOE site visit for the purpose of validation and inspection. Two (2) calibration modes involved which are:
  - i. Direct calibration mode (calibration gases direct to analyzer). This applies during Zero and Span Check; and
  - ii. System calibration mode (Direct injection of calibration gas to the probe and flow throughout the whole CEMS system). This applies during Functional Test/QAL2/QAL3/AST.

4.1.21 The brand and model of each CEMS component installed must follow as specified in the certificate. Should any change be required, the applicant must provide supporting references for DOE evaluation as below:

- a) Comparison of specification and performance between the original certified component and the alternative brand/model. The alternative component must show equivalent to the original.
- b) The alternative brand/model of components are certified with other certified CEMS; or/and
- c) Evidence of third-party (QAL1 certified) testing showing the alternatives components works with the CEMS.

This information is to be provided during CEMS application made via DOE system for CEMS.

4.1.22 As industrial processes often differ in their requirements, some flexibility is allowed in the selection of the sampling system with the CEMS. However, extractive CEMS must not deviate from the type of sampling system specified in certificate to ensure CEMS is not degraded, such that it no longer meets the required performance specifications (void QAL1). Such allowable variations could include:

- a) A different length of sampling line to that which was tested will be depending on the site requirement.

- b) A different brand or model of sampling train, so long as there is evidence from third-party testing that the alternative components meet the required performance specifications and have been tested on analogous system. Supporting documents as specified in the item (4.1.21 a & b) are also required.

Example:

A certified permeation dryer may replace an existing permeation dryer; however, a chiller-dryer would not be accepted unless its performance could be proved to be equivalent to the original, either through MCERTS/TUV testing or witness test data or parallel measurement.

- c) Additional manifolds and heated valves used to allow more than one analyzer to share a sampling train.

Example:

A combination of multiple analyzers to a sampling system

- d) Industry or activity that requires correction to gas reference (Oxygen) under the CAR 2014 or any provision under the EQA 1974 is required to install an Oxygen MCERT or TUV certified analyzer. CEMS multi gas analyzer that can measure Oxygen is highly recommended.

4.1.23 Enclosures – One important aspect of CEMS designs is the CEMS enclosure in which CEMS is housed. This provides protection, all services required for operation and safe access. Types of enclosure can vary as simple as a simple cover through, or a cabin and the chosen type should consider the CEMS location and the environment that CEMS will be operating. This component is not necessary but highly encouraged by DOE to safeguard the CEMS.

4.1.24 The data acquisition handling system (DAHS) of CEMS shall be able to perform basic functions which include those associated with system control (if applicable), data acquisition and correction and data handling function such as display, recording and reporting as mentioned in subchapter 3.4 of this guideline.

4.1.25 CEMS is categorized as a “control equipment” under the Environmental Quality Act 1974. Hence, all measurements from CEMS must be retained on file by the operator for at least 3 years as required under the Reg. 10, CAR 2014.

## 4.2 Installation Specifications

4.2.1 Three (3) overriding principles for CEMS installation are:

- a) The measurements must be representative of the actual stack emission. Dilution of emissions is prohibited under Reg. 14 of CAR 2014.
- b) The effluent gases are well mixed.
- c) The sampling location should be accessible for system maintenance and repairs.

4.2.2 CEMS measurement location.

4.2.2.1 The measurement location shall follow specifications below as a guide to facilitate the installation of CEMS at representative locations. Minimum requirements of five (5) equivalent internal stack diameter downstream and five (5) equivalent internal stack diameter upstream of any flow disturbances are explained below:

- a) Five (5) equivalent internal duct diameter downstream and two (2) equivalent internal duct diameter upstream of any flow disturbances. The duct is meant for emission exhaust or/ and shall be able to represent the final emission.

b) For Opacity or PM (in-situ system), the consideration below must be considered when selecting measurement location which are:

- i. Water droplets (condensed water vapor) are not to be present at the monitoring location.
- ii. If the monitor responds to ambient light, it is to be located at a point where ambient light is not present (away from either the top of the stack or where light leaks into the ductwork)

4.2.2.2 The above-mentioned requirements are elaborated further in the Malaysian Standard 1596 – Determination of concentration and mass flow of particulate matter in flue gas for stationary source emissions document.

4.2.3 Other location requirements for CEMS include (and are not limited to):

- a) Ideally to locate PM CEMS above the area where the gas CEMS is located;
- b) CEMS to be located downstream of the periodic monitoring or standard reference method (SRM) sampling location;
- c) Being downstream from any abatement system;
- d) Being downstream from any merging ducts;
- e) Each CEMS should monitor a single stack/chimney; and
- f) As far from the final exhaust as practicable.

4.2.4 Any new stack that is built after the commencement of these guidelines shall

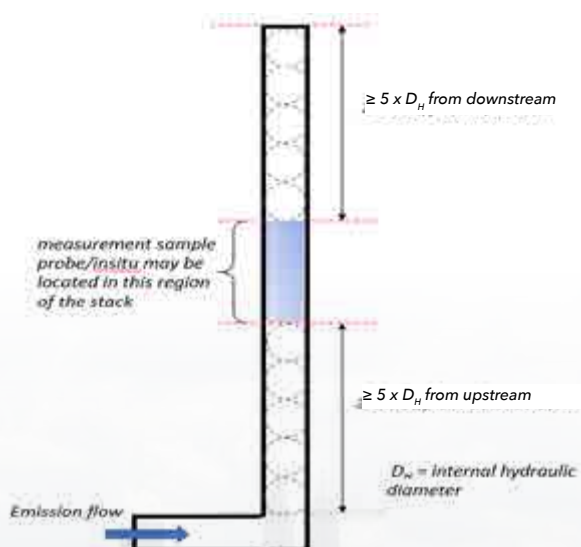

Figure 4.1 - Sampling probe location

follow CEMS location criteria as mentioned above. However, exemption can be given to stack:

- a) Which has obtained Written Approval (Kelulusan Bertulis) under the CAR 1978 and meeting the USEPA stack sampling location criteria which is 8D downstream, 2D upstream (for dust and gas) and 2D downstream,  $\frac{1}{2}$  D upstream (for gas only).
- b) Has conducted homogeneity test/stratification test/stack flow modelling and passed the test with no stratification found. This test shall be conducted by using any of the applicable procedures listed below:
  - Homogeneity test:  
EN 15259 – Air Quality- Measurement of Stationary Source Emission- Requirements for Measurements Sections And Sites And For The Measurement Objective, Plan And Report.
  - Stratification test:  
US EPA Chapter 2 Bias Due to Probe Location and Stratification.

4.2.5 The monitor or probe is to be accessible to permit routine maintenance. Accessibility is also important for the performance of calibration audits and alignment checks. Hence, an appropriate design of CEMS platform is required to enable any calibration work, routine maintenance and operational checks of CEMS to be executed.

4.2.6 For Point CEMS sampling system, the measurement point shall be

- a) No less than 1.0 meter from the stack or duct wall or
- b) Centrally located over the centroidal area of the stack or duct cross section as illustrated in **Figure 4.2**

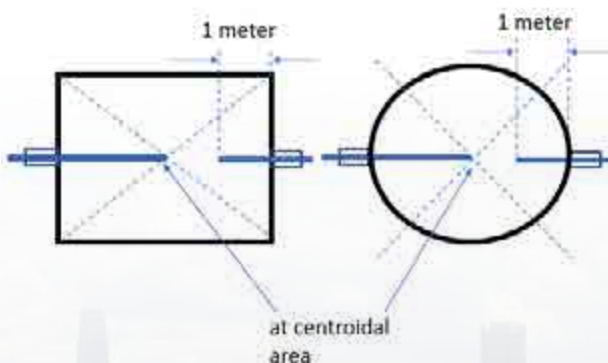

**Figure 4.2 – Measurement point for Point CEMS**

4.2.7 For Path CEMS sampling system, the measurement path shall be

- a) Totally within the inner area bounded by a line 1 meter from the stack or duct wall or
- b) Have at least 70 percent of the path within the inner 50 percent of the stack or duct cross-sectional area, or
- c) Centrally located over any part of the centroidal area as illustrated in **Figure 4.3**

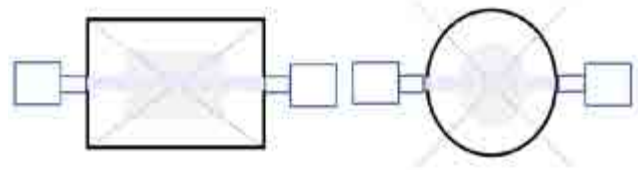

**Figure 4.3 – Measurement point for Path CEMS**

4.2.8 Standard Reference Method (SRM) measurement location shall be prepared accordingly same to para 4.2.2 for quality assurance purpose of CEM system.

4.2.9 Plant operator to ensure availability of permanent, strong & reliable platforms at CEMS monitor/probe mounting location with safe approach ladders or staircase or elevator.

4.2.10 All the power cables, signal cables, instrument air tubing's shall be properly laid & clamped.

4.2.11 All CEMS components shall be labelled and schematic diagram of CEMS shall be displayed at appropriate CEMS location (CEMS shelters/cabinet) for reference.

# Chapter 5 ►

## CEMS Quality Assurance Programs

### 5.1 Quality Assurance Programs

5.1.1 A Quality Assurance Program is basically a management program developed to assure that Quality Control (QC) activities are performed. These QC activities such as daily calibration, regularly performance audits and maintenance activities should be comprised as a set of standard operating procedures (SOPs), which are then incorporated into a Quality Assurance Plan (QAP).

5.1.2 A Quality Assurance Plan (QAP) shall be in a documented written form (and later become a QA manual), implemented, maintained and followed. It must include and describe a complete program of activities to be implemented to ensure data generated by the CEMS are complete, accurate, precise, traceable and reliable.

5.1.3 The outline for a CEMS QA manual is given in **Table 5.1**. Other procedures can be instituted to further assure the accuracy and precision of the CEMS data.

5.1.4 The QA manual as outlined in **Table 5.1**, must satisfy the Quality Assurance and Quality Control of CEMS as listed below which are necessary to ensure accuracy, precision, traceability and reliability of the CEM data and information of all the time:

- a) **Design and Installation Requirement** –
  - i. is a process which suitable CEMS is selected. This requires a procedure to demonstrate to DOE that the CEMS is potentially suitable for its purpose before installation.
  - ii. In this case, appointed CEMS consultant is responsible to propose the most suitable CEMS by considering important aspects but not limited to plant process, parameters to be monitored, stack condition and emission characteristics.
  - iii. The CEMS installation criteria as described in Chapter 4 of this guidelines.
- b) **QAL2 - Calibration and Variability Test (QAL2-CVT)** – A procedure for calibrating CEMS against the appropriate Standard Reference Method (SRM). The SRM is deemed to provide the correct results within certain tolerances. The process also verifies the installation of the CEMS through functionality testing, and that it meets the measurement uncertainty requirements.
- c) **QAL3 - On-Going Performance Monitoring (QAL3-OGPM)** – QAL3 addresses the ongoing quality assurance of the CEMS in operational use. It requires the operator to ensure that zero and span measurements are carried out periodically. The results of these measurements are used in a control procedure, examples of which are Shewhart or CUSUM control charts, to check that the CEMS has not drifted out of control, and that precision has not deteriorated. If the CEMS exceeds pre-determined alarm limits, it is deemed

**Table 5.1 – Outline for a CEM System Quality Assurance Manual**

No	Outline for CEMS Quality Assurance Manual
1	CEM regulatory mandates and CEMS description
2	Organization and responsibilities
3	Facilities, equipment and spare parts inventory
4	CEMS operating manual
5	Functional Test procedure
6	QAL2 - Calibration and Variability Test (CVT)
7	QAL3 - On-Going Performance Monitoring (OGPM)
8	Annual Surveillance Test (AST)
9	Corrective action procedures
10	System audit procedures
11	Data backup procedures
12	CEMS security
13	Data reporting procedure
14	Reference (Gas CoA, reference material CoA, auto calibration cell CoA, etc)
15	Blank form (including Emission Excess and CEMS Failure notification form)

to be out of control resulting in a QAL3 failure. Adjustment or maintenance of the CEMS will be required.

- d) Annual Surveillance Test (AST)** – A procedure to evaluate CEMS on a yearly basis to show that it continues to function correctly, the calibration function remains valid, and that the variability remains within acceptable levels. The process involves carrying out functionality testing and parallel measurements on the CEMS.

5.1.5 These quality assurance levels follow a logical sequence and aim to demonstrate the correct selection, installation, calibration and continuously valid operation of the CEMS at plant operator's facility. These are shown in **Figure 5.1**

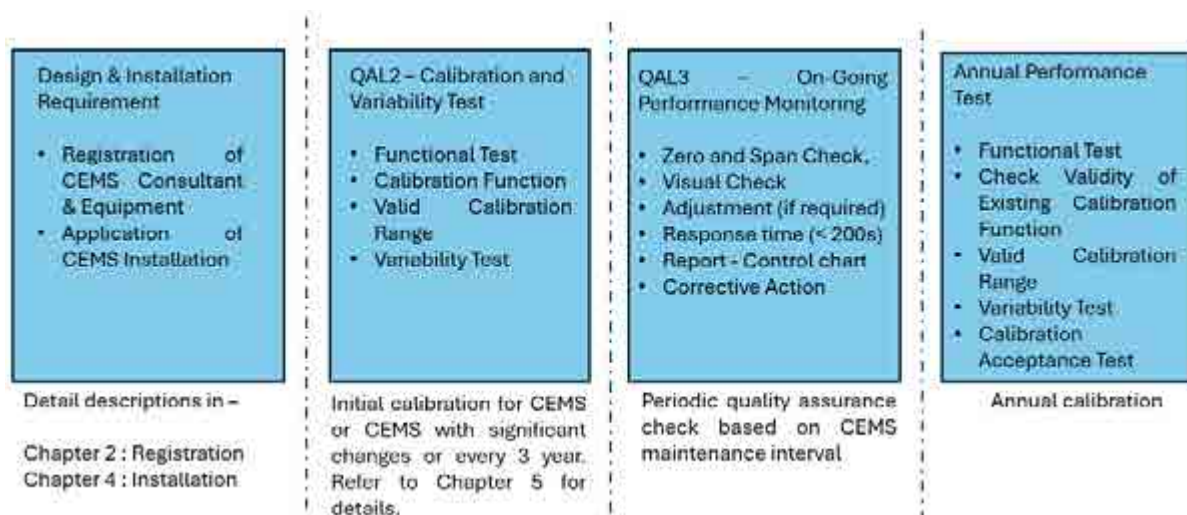

**Figure 5.1: The Sequence of Quality Assurance and Quality Control activities for CEMS**

## 5.2 Functional Test

5.2.1 Functional tests are a series of checks carried out on the CEMS. The functional test shall be performed not more than one month before parallel measurements between CEMS and SRM are started.

5.2.2 Functional test result validity is within one month of QAL2 CVT/AST execution. If QAL2 CVT/AST performed shifted from specified period due to an unavoidable event or circumstances, then CEMS tester shall inform the plant operator that they should provide verifiable evidence to demonstrate the FT test result are still valid. The evidence shall include performance test such as QAL3 data to demonstrate that the performance of CEMS is not changed between the functional

test and parallel measurement. Such test shall include zero and span data for the entire sampling system and analyzer. The CEMS tester shall include these data in the QAL2 and AST report, as applicable.

Plant operator shall inform DOE to proceed in this manner and no QAL2 or AST shall be conducted prior getting consent from DOE.

5.2.3 Unavoidable events or circumstances referred to the clause 5.2.3 are only limited to:

- Sudden plant failure and corrective actions needed. Some may require longer period before plant ready to resume operation.
- Bad weather or monsoon season which affecting the testing site.
- Plant is operated intermittently due to insufficient load or only operates on-demand based.

Any situation which requires delay of QAL2 or AST shall not exceed 2 months from the date of Functional Test is last conducted and subject to DOE approval. Should the Functional Test has expired from this specified period, a new Functional Test shall be conducted.

5.2.4 Plant operator is responsible to ensure Functional Test is conducted prior QAL2 or AST. The Functional Test shall be performed by CEMS tester and CEMS consultant which must be witnessed by the plant operator.

Note 1: CEMS consultant is referred to the company which is responsible for the installed CEMS or any DOE registered CEMS consultant with the same CEMS brand/model registration.

- 5.2.5 The requirements for Functional Tests are listed in **Table 5.2**.
- 5.2.6 Functional Test is also required for diluent such as oxygen and moisture (if applicable). The criteria for the test shall be based on the MCERT performance specification. Certified calibration gas with suitable concentration shall be provided by the plant operator.
- 5.2.7 The Functional Test shall be assessed and validated prior to conducting the parallel reference test required by QAL2 and AST. Any necessary corrective actions shall be addressed before the CEMS tester performs the parallel reference test. QAL2 or AST execution prior corrective action is taken is not permitted.
- 5.2.8 **Table 5.2** shows additional guidance describing each activity required during the test and Functional Test format report is as in **Appendix 1**.

**Table 5.2 – The requirements for Functional Tests**

Functional Test Activity	CEMS Type	
	Extractive CEMS	In-Situ CEMS
Alignment & cleanliness		/
Sampling Train	/	
Documentation and records	/	/
Serviceability	/	/
Leak Test	/	
Zero and span check	/	/
Linearity	/	/
Interferences	/	/
Zero and span drift (audit on On-Going Performance Monitoring)	/	/
Response time	/	/
Report	/	/

### 5.3 Calibration and Variability Test (QAL2-CVT)

5.3.1 Calibration and Variability Test is the test required to accept or certify CEMS installation and operation at the plant and shall be conducted prior CEMS data connection to DOE system for CEMS can be made. Unaudited CEMS data transmitted to DOE are considered unverified and invalid.

- 5.3.2 QAL2-CVT procedure is required to carry out on installation in the following situations
  - a) Within 6 months of the commissioning of a new CEMS.
  - b) At least every three (3) years for all CEMS installation required under CAR, 2014 or any provision under the EQA 1974.
  - c) If QAL3-OGPM evaluation or AST demonstrates a need for a QAL2-CVT;
  - d) After any CEMS failure/malfunction or if there are modifications, upgrades or repairs to the CEMS, which will influence and change the results significantly. Significantly can be interpreted as a change which causes the subsequent QAL3 tests to fail.
  - e) If there is a change of fuel (see following paragraph 5.3.3). Plant based biomass fuel may have different properties for each batch and may alter the flue gas emissions. It thus, potentially requires QAL2 to be conducted each year instead of AST.
  - f) Whenever there is a significant change in plant operation, which changes the emissions.
  - g) If the CEMS exceeds the limits for operating outside the valid calibration range (see following paragraph 5.3.5).
  - h) If the CEMS previously tested by using procedures other than EN 14181 requirement and no calibration function to be verified during AST. (RATA, CGA, RCA etc.)
- 5.3.3 Changes to the plant or fuel can influence the emissions profile of the process and may require a new QAL2-CVT procedure. The following is considered as significant change in fuel:
  - a) The change in fuel alters the flue gas emission profile.
  - b) The change in fuel results in a licence revision.
  - c) The fuel is changed from one to another of the following types – solid, liquid, and gaseous.
  - d) The fuel is changed from a single type to a mixture of fuel types, or vice versa.
  - e) The thermal input is more than 10% per year for the alternative fuel.
- 5.3.4 If there are significant changes to plant or fuel (as mentioned in 5.3.3), the plant operator can prove that the calibration

function is still valid (not change), by performing AST within 30 days to provide evidence. If the plant operator is confident that the calibration function has not changed, then an AST can be performed to provide the evidence.

5.3.5 Once the need for a new QAL2-CVT has been triggered, the new calibration function shall be implemented as soon as practicable but within three (3) months. During this time the previous calibration function must be used until the new calibration function has been determined.

5.3.6 This QAL2-CVT procedure shall be conducted by a CEMS tester registered with DOE, who is able to conduct parallel measurement CEMS with SRM, then to determine calibration function, valid calibration range and variability test.

5.3.7 CEMS initial setting (during installation) for PM shall be conducted separately from QAL2 testing and must follow procedures specified in the manual or method specified by the manufacturer.

Note: At least minimum 5 runs (or as specified by the manufacturer) of data to be collected and able to represent the emission profile. Sampling procedure shall refer to MS 1596 / EN 13284-1.

5.3.8 Calibration function test procedure:

- a) Calibration function test required parallel measurement CEMS with SRM. The use of reference materials alone to obtain calibration function is not permitted. This is because, these reference materials do not replicate sufficiently the stack gas matrix.
- b) Required at least 15 parallel measurements spread uniformly over three (3) days when the plant operates normally and every each of the measuring days of normally 8 hours to 10 hours. The three (3) days do not need to be consecutive but must performed within a period of at most 4 weeks.
- c) Should the parallel measurements require more than 3 days and less than 15 runs of SRM to be conducted due to any unavoidable and unforeseen circumstances, plant operator shall be in informed by the CEMS Tester and inform DOE State via any available platform

(phone, email or letter) to seek consent. This consideration is only allowed for any of the following conditions:

- a. Shorter plant operating time (less than 8 to 10 hours daily) which requires to prolong the measurement period in order to get a sufficient and representative SRM data.
  - b. Sudden plant failure and corrective actions needed.
  - c. Bad weather or monsoon season which affecting the testing site.
  - d. Plant is operated intermittently due to insufficient load or only operates on-demand based.
- d) Plant operator and CEMS tester shall select a time when the emissions are likely to be at the highest and most varied. However, an industrial process may not be deliberately varied outside normal operational conditions, to create higher than normal emissions.
  - e) To ensure that the calibration function is valid for the range of conditions within which the plant will operate, the concentrations during calibration shall be varied as much as possible within the normal operations of the plant. This shall ensure that the calibration of the CEMS is valid over a large range as possible but still cover most operational situations.
  - f) However, an industrial process may not be deliberately varied outside normal operational conditions, to create higher than normal emissions unless if permitted through a license to contravene under the provision of CAR 2014.
  - g) The sampling time for each parallel measurement shall be at least 30 minutes and time interval between the start of each sample shall be at least 1 hour.
  - h) The results obtained from the SRM must be expressed under the same conditions with CEMS measured data (e.g. pressure, temperature etc.)
  - i) SRM measurements may require manual sampling and calculation of water vapour concentration for Hot/Wet CEMS audit.
  - j) The calibration procedure needs a good spread of concentrations to provide

reliable calibration function. This approach may not be possible due to process type and plant conditions. For that, one (1) of three (3) situations, will arise during parallel measurement and will have different procedure to calculate calibration function. This summarizes in **Table 5.3**.

- k) Lag time – CEMS tester shall have procedure to determine the lag times and for matching the data from CEMS and SRM accordingly.
- l) Outliers data – CEMS audit tester shall eliminate any outlier data by conducted outlier test. Reason for exclusion of outliers shall be reported. However, if calculate coefficient of calibration function;  $R^2 > 0.90$ , then is not necessary to perform an outlier test.
- m) Total valid data points must be at least 15 and exclusion of any outlier data must be considered, or else this requirement can be failed and the QAL2 is invalid. Hence, additional data points need to be taken. It is advisable to obtain 18 Or 19 sets of data to ensure sufficient valid data sets available.
- n) At least one (1) of 15 data must be at zero or near zero (near zero defined as value 5% or less of ELV). Zero values should be measured when the installation is not producing emissions. If this is not possible, then reference materials shall be used to determine the CEMS's response to zero values of the emissions pollutant.
- o) Calibration function for NO<sub>x</sub> - **Table 5.4** summarises the approach to use generating calibration function for NO<sub>x</sub>.
- p) Calibration function of Oxygen and Moisture –
  - i. Not necessary if emissions pollutant is passing the variability test.
  - ii. If not, same QAL2-CVT procedure are required for Oxygen and Moisture to conduct calibration function and variability test; by referring:
    - O<sub>2</sub> ELV = 21% and 95% CI = 10% ELV and
    - Moisture ELV=30% and 95%CI = 30% ELV
  - iii. If CEMS reading for moisture shows error when compared to SRM moisture reading, then the SRM

result shall be used in the QAL2 of CEMS which measures moisture.

- iv. CEMS for oxygen and moisture (if used) must be certified by MCERT or TUV and same applied to the SRM that uses instrumental techniques.
- q) Calculate the calibration function –
  - i. As guidance, an indicator for a valid calibration function is a correlation coefficient of the regression line of  $R^2 = 0.9$  or more.
  - ii. However, this guideline may not work for lower-level emissions. Hence, an  $R^2$  of less than 0.9 does not necessarily indicate a QAL2 failure when the emissions are low level cluster.
  - iii. The variability test shall always be considered as the definitive test.

#### 5.3.10 Valid calibration range-

- a) The calibration function is valid when the plant is operated within the valid calibration range (VCR).
- b) VCR is determined at the same time the calibration function is calculated where highest calibrated CEMS parallel measurement at standard conditions plus 10% for gas (or plus 100% for particulate CEMS) of the ELV or 20% ELV, which ever greater.

#### For Gas :

$$\text{Valid calibration range (VCR)} = 0 \text{ to } 110\% \times \text{CEMS}_{\text{calibrated, std condition}}$$

#### For Dust :

$$\text{Valid calibration range (VCR)} = 0 \text{ to } 200\% \times \text{CEMS}_{\text{calibrated, std condition}}$$

- c) The calibration range may also be extended to the ELV for gas, if suitable reference material is available. The extrapolation is valid if the difference between a reference material measurement at the ELV and the extrapolated calibration line at the ELV is less than uncertainty specified in the regulation. The difference at zero shall be less than 10% of the ELV.
- d) For measurements outside the VCR, the calibration curve shall be extrapolated to determine the concentration values, which exceed the VCR, limited to ELV.
- e) If CEMS measured values exceed the valid calibration range, a new QAL2-

CVT may be required. This is necessary if either of the following occurs:

- i. More than 5% of CEMS calibrated and standardised values during a weekly period are outside the valid calibration range for more than five weeks between two AST.
- ii. More than 40% of CEMS calibrated and standardised values during a weekly period are outside the valid calibration range for one or more weeks.

If the plant is not operated continuously then the percentage values may be calculated from the last 168 operational hours, which representing one week in operation.

- g) If exceedances of the VCR are caused by plant failures, a full new calibration (QAL2) is not needed after fixing the plant failure.
- g) The validity of the valid calibration range shall be evaluated by the plant owner on a weekly basis.

#### 5.3.9 Variability Test –

- a) The test shall be based on stack measurement only. It shall not use data obtained from reference material.

- b) Carry out variability test and then do assessment (pass-fail criteria) for variability result. **Table 5.5** list all related variability test equation and criteria.
- c) The quality of SRM application will influence the test result. Therefore, an imprecise implementation of the SRM can result a poorer variability of the CEMS and could result in its false rejection during the variability test.

5.3.10 **Figure 5.2** shows the summary in flow chart for conducting Calibration and Variability Test begin with Functional test until Variability Test.

5.3.11 The Calibration and Variability Test report shall be prepared submitted to DOE for verification. The test report shall be well organized, readable, and complete. All data, including softcopy and hardcopy raw data necessary to recalculate any of the reportable parameters, should be included in the report. Appendix 2 listed the items that are to be reported



**Table 5.3 – Situations arise during parallel measurement and procedure to determine calibration function.**

Situation Arise	Procedure to determine calibration function
<p>Situation 1 - Good spread of data. The dataset is deemed to have a widespread when the difference between the highest and lowest SRM parallel measurements at standard conditions is greater than the maximum permissible uncertainty.</p> <p><b>(SRM<sub>max</sub> - SRM<sub>min</sub>) &gt; 95%CI of daily average ELV</b></p>	<p><b>Use procedure A</b></p> <p>Requires confirmation of CEMS can read zero (during plant turned off or use surrogate zero)</p> <p>Calibration Function equation:</p> $y = bx + a$ $b = \frac{\sum_{i=1}^n (x_i - \bar{x})(y_i - \bar{y})}{\sum_{i=1}^n (x_i - \bar{x})^2}$ $a = \bar{y} - b\bar{x}$ <p>where <math>y = \text{CEM}_{\text{calibrate}}</math>, <math>x = \text{CEM}_{\text{measure}}</math></p>
<p>Situation 2 - High-level cluster, this occurs when there is little variation in emissions. A data set is defined as a high-level cluster when the difference between the highest and lowest SRM parallel measurements at standard conditions is less than the maximum permissible uncertainty, and the lowest SRM parallel measurement at standard conditions is greater or equal than 15% of the ELV.</p> <p><b>(SRM<sub>max</sub> - SRM<sub>min</sub>) &lt; 95%CI of daily average ELV and SRM<sub>min</sub> ≥ 15% of daily average ELV</b></p>	<p><b>Use procedure B</b></p> <p>Requires confirmation of CEMS can read zero when the emissions are zero during plant turned off or use surrogate zero if the process variations do not provide zero readings.</p> <p>Calibration Function equation:</p> $y = bx + a$ $b = \frac{\bar{y}}{\bar{x} - z}$ $a = -\bar{b}z$ <p>where</p> <p><math>y = \text{CEM}_{\text{calibrate}}</math>,  <math>x = \text{CEM}_{\text{measure}}</math></p> <p><math>z = \text{offset; difference between CEMS}_{\text{measure}} \text{ zero reading value and zero}</math></p>
<p>Situation 3 - Low-level cluster, this occurs when emissions are controlled. A data set is defined as a low-level cluster when the difference between the highest and lowest SRM parallel measurements at standard conditions is less than the maximum permissible uncertainty, and the lowest SRM parallel measurement at standard conditions is less than 15% of the daily ELV.</p> <p><b>SRM<sub>max</sub> - SRM<sub>min</sub>) &lt; 95%CI of daily average ELV and SRM<sub>min</sub> &lt; 15% of daily average ELV</b></p>	<p><b>Use procedure C</b></p> <ol style="list-style-type: none"> <li>Calibration function not reliable if coefficient of the regression (<math>R^2</math>) <math>R^2 \leq 0.9</math> for gaseous compounds or 0.5 for dust. However, the variability test result shall always be considered as the definitive test.</li> <li>Using surrogates and linearity data to calibrate the CEMS. If appropriate, surrogate at zero and close to the ELV shall be used to obtain two (2) data pairs with the CEMS measured reading or data pairs available from the functional test can be used as well. This only applies to gas.</li> <li>Reference material for this calibration purpose must be certified.</li> <li>Linearity data then used to determine calibration function using Procedure A.</li> </ol> <p>For particulate PM, if CEMS audit test found that it is not possible to determine a meaningful calibration function (e.g.: most or all the reported PM values are at or near zero especially when the industrial process is equipped with bag filters). Determination of calibration function for this situation is as discussed in the next paragraph.</p> <ul style="list-style-type: none"> <li>Surrogates may be useful for zero, span and linearity tests but those results cannot mimic CEMS reading of PM, thus it is precluded from Procedure C.</li> </ul>

**Determination of Calibration Function For Low Level Cluster Particulates**

1. Clusters are classed as low level when the difference between the highest and lowest standardised SRM reading is smaller than the maximum permissible uncertainty and the lowest standardised SRM reading is smaller than 15% of the daily ELV.
2. There are three options available to set up particulate monitoring CEMS for monitoring emissions if the SRM data is not sufficiently high to calibrate the CEMS using the principles of linear regression analysis which are:
  - 2.1 If the average particulate emissions recorded using the SRM are greater than the uncertainty of the SRM, then use the average value to calibrate the CEMS and example is as below:
    - a) Calculate the average SRM reading. Example, 0.6 mg/m<sup>3</sup>.
    - b) Calculate the average CEMS reading. Example, 1.1 mg/m<sup>3</sup>.
    - c) Calculate the CF by using this formula:  $\text{SRM Result} = 0.6 = 0.55$  (referred as 'b')  
CEMS result = 1.1
    - d) So, the CF would be  $y = bx+c$  and  $y = 0.55x + 0$
    - e) Once the calibration function has been derived, then carry out the variability test

Note : Uncertainty of SRM = 20% of ELV

- 2.2 If there are sufficient data available from the site, or from similar sites with higher emissions, then the CEMS supplier or CEMS tester can calibrate CEMS based on experience and best estimate of the CEMS's response to expected concentrations.
- 2.3 If there are no data available to calibrate CEMS by the above methods, then the particulate monitor cannot be used as quantitative monitor but can serve as a qualitative indicator.

Recommended method:

- a) If emission is consistently low, SRM is used to verify the low emission.
- b) Use surrogates to check linearity.
- c) Zero and span settings of the monitor.
- d) Set monitor to its most sensitive range to alert the operator that the control devices for particulate may need attention if an increase of emission is observed.

**Table 5.4 – Generating calibration functions for NOx**

CEMS	SRM	Approach
NO	NO	Generate a calibration function for NO
NO	Total NOx	Generate a calibration function for NO using the measurements for Total NOx, bearing in mind that the calibration function should implicitly include the proportion of NO <sub>2</sub> in the stack
NO + NO <sub>2</sub>	Total NOx	a. Convert the NO + NO <sub>2</sub> to Total-NOx and generate calibration function.
Total NOx	NO + NO <sub>2</sub>	b. If measurement in mg/m <sup>3</sup> , NO must be multiplied with 1.53 before adding in to NO <sub>2</sub> to become Total NOx. NOx (mg/m <sup>3</sup> ) = NO x 46/30 + NO <sub>2</sub> (mg/m <sup>3</sup> ), if measured separately.
NO + NO <sub>2</sub>	NO + NO <sub>2</sub>	

**Table 5.5 - Related variability test equation and criteria**

No	Variability Test	Formula
1	Standard Deviation of the difference of SRMstd cond and CEMS calibrated, std cond; Sd	$S_d = \sqrt{\frac{1}{n-1} \times \sum_{i=1}^n (D_i - \bar{D})^2}$ <p> <i>n</i> = number of measurements  <i>S<sub>d</sub></i> = standard deviation of the difference <i>D<sub>i</sub></i>  <i>D<sub>i</sub></i> = SRMstd cond - CEMS<sub>calibrated, std cond</sub>  <i>D</i> = average of difference                 </p>
2	Test of variability	Variability accepted if $S_d \leq \sigma_o \times k_v$ <i>k<sub>v</sub></i> = test parameters refer to number of parallel measurements; refer to below table $\sigma_o$ = uncertainty laid down by authorities at 95% CI daily ELV, where $= \frac{\text{daily ELV} \times \text{measurement uncertainty; 95\% CI}}{1.96}$ measurement uncertainty: 95% CI refer to <b>Table 4.1</b> <b><i>k<sub>v</sub></i> value table</b>

Number of parallel measurements (N)	<i>k<sub>v</sub></i> (N)	<i>t<sub>0.95</sub></i> (N-1)
3	0.8326	2.353
4	0.8881	2.920
5	0.9161	2.132
6	0.9329	2.015
7	0.9441	1.943
8	0.9521	1.895
9	0.9581	1.860
10	0.9629	1.833
11	0.9665	1.812
12	0.9695	1.796
13	0.9721	1.782
14	0.9742	1.771
15	0.9761	1.761
16	0.9777	1.753
17	0.9791	1.746
18	0.9803	1.740
19	0.9814	1.734
20	0.9824	1.729
25	0.9861	1.711
30	0.9885	1.701

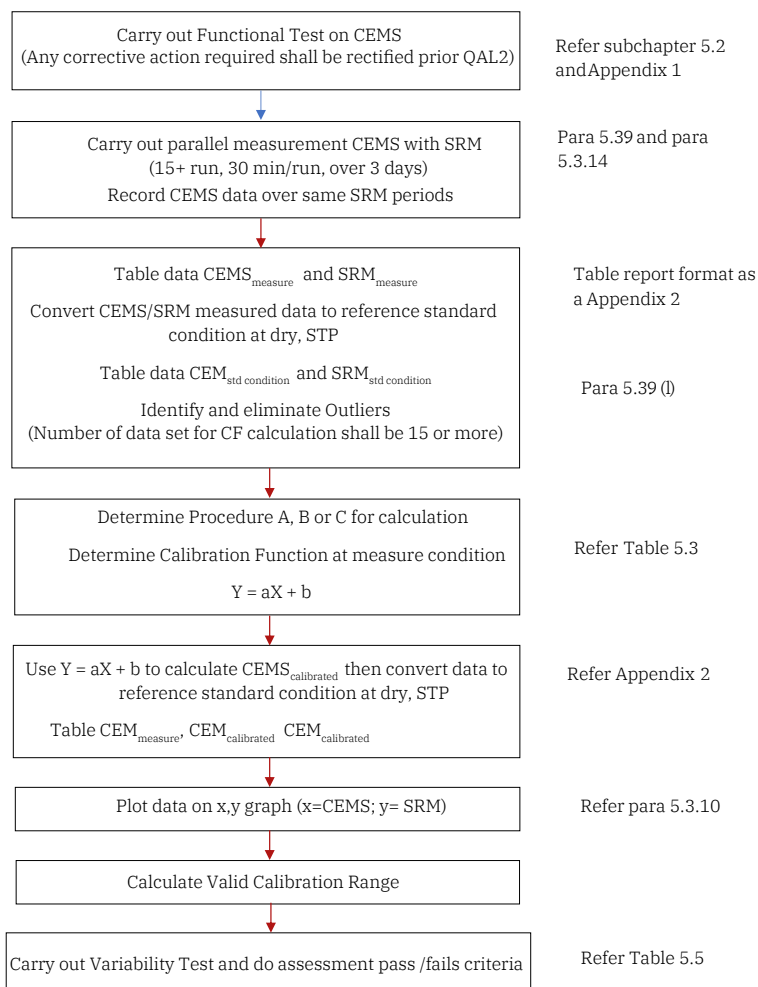

**Figure 5.2 - Flow Chart for Calibration and Variability Test of CEMS**

\*For Annual Surveillance Test – required (5+ run, 30 min/run)

5.3.14 Standard Reference Method:

- a) DOE recognizes the standard methods adopted from MS, USEPA, CEN, ISO or any approved method to be used as Standard Reference Method (SRM) by CEMS audit tester.
- b) Only DOE registered CEMS tester can conduct parallel measurement CEMS with SRM for QAL2-CVT and AST testing.
- c) Monitoring systems used within SRMs must gained approval and registered with DOE and meet the performance criteria which follow one or more of the international standards below:
  - i. United Kingdom Monitoring Certification Scheme (MCERTS) – EN15267-4 & EN14181 QAL1 for Transportable CEMS (T-CEMs)
  - ii. German Technical Inspection and Monitoring Union (TUV) QAL1-EN15267-3 & EN14181 QAL 1 portable AMS (P-AMS)

- iii. Malaysian Standard MS 2564:2014 - Performance Criteria and Test Procedure For CEMS- Annex F (Transportable System)

5.3.15 Standard Reference Method Measurement Location and Traverse Point:

- a) RM sampling port shall be prepared accordingly same as CEMS probe/in-situ location as mentioned in subchapter 4.2.2. In addition, RM shall not interfere with CEMS probe/in-situ location. A distance of 30 cm (at minimum) and is specified as an appropriate separation.
- b) For duct or stack less than 2.4-meter diameter, RM testing is performed on a three (3) traverse points; that are 16.7%, 50% and 83.3% of the line as illustrated in Figure 5.3(a) for gas measurement – Usual practice only uses 1 point.
- c) If duct or stack with measuring line diameter greater than 2.4 meter and stratification is not expected, sampling

may conduct at 0.4, 1.2 and 2.0 meter as illustrated in **Figure 5.3(b)** for gas measurement. [This option not allowed after wet scrubbers or at a combined gas stream (from two or more streams) with difference pollutant composition combine]

- d) If stratification is expected, the alternative traverse point location, mentioned in 5.3.5 (c) may not be use and must use three (3) traverse point as mentioned in 5.3.5 (b) or other traverse points that can be shown and satisfied by DOE base on stratification test.
- e) In Malaysia, common method used for PM CEMS SRM is as specified in the Malaysia Standard MS 1596 - Determination of Concentration and Mass Flow of Particulate Matter in Flue Gas for Stationary Source Emissions. For alternative, any other suitable and recognized method as mentioned in sub-chapter 5.3.14 (a) is permitted.
- f) Conduct all necessary SRM test within 3 cm of the traverse points, but no closer than 3 cm to the stack or duct wall.

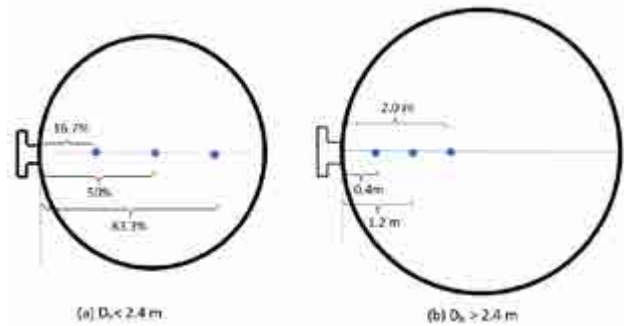

**Figure 5.3 – Reference method traverse points on a measurement line**

### 5.4 QAL2 Implementation

- 5.4.1 Plant operator shall implement the Calibration Function in the CEMS DAHS for all parameters which have been obtained during the QAL2-CVT and approved by DOE prior the implementation.
- 5.4.2 Depending on the type of CEMS installed, the Calibration Function can be set either in the analyzer or applied as a correction to results in the DAHS. Training of this calibration function application into the analyzer software/data handling system shall either be provided by the CEMS consultant to the plant operator or be available to carry this out themselves.
- 5.4.3 The sequence of data treatment should be as follows:



DAHS

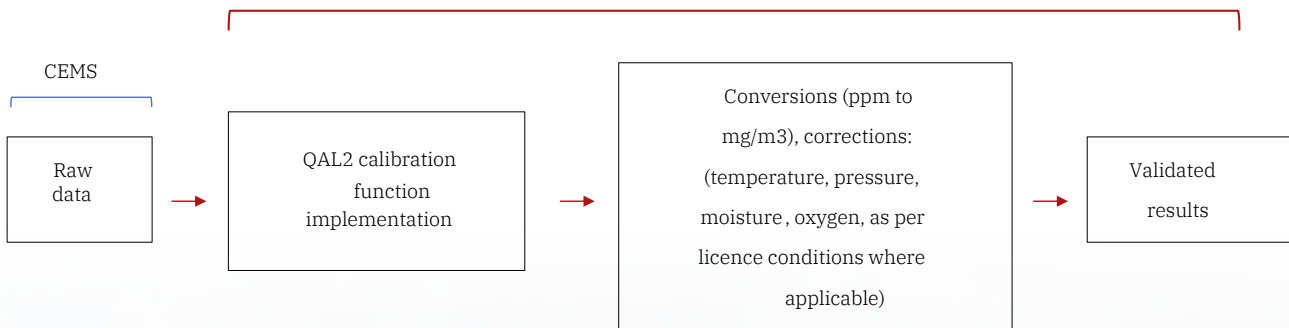

## 5.5 QAL3 - On-Going Performance Monitoring

- 5.5.1 On-going Performance Monitoring (QAL3-OGPM) procedures are responsibility of plant operator for monitor CEMS during its operation by assessing the drift, response and precision of the instrument.
- 5.5.2 The implementation and performance of the QAL3 procedures are the responsibility of the plant operator or any in-house personnel in charges CEMS. If required, plant operator may appoint any registered CEMS consultant with the same registered CEMS equipment brand/model to conduct the QAL3-OGPM.
- 5.5.3 The plant operator is also responsible to ensure the CEMS is operating inside the valid calibration range (VCR) as obtained in the Initial QAL2-CVT.
- 5.5.4 It is recommended that these procedures commence as soon as possible after the installation of the CEMS to gain as much information on the performance of the CEMS as possible. This may begin before the CEMS has to be calibrated with the SRM to fulfil the QAL2 procedure requirement.
- 5.5.5 **Zero and Span Drift Check**

Plant operator requires to ensure that zero and span drift check and response time are carried out periodically based on the maintenance interval. The results shall be recorded and follow the performance criteria as mentioned in **Table 5.6**.

**Table 5.6 – Performance Criteria of Gases and Particulate CEMS**

Emission Gases	Performance Characteristic		
	Response Time	Zero Drift	Span Drift
Gases except O <sub>2</sub>	< 200 s (<400 s for HCL & HF)	≤ 3.0 %	≤ 3.0 %
Oxygen; O <sub>2</sub>	< 200 s	≤ 0.2 %	≤ 0.2 %
Particulate Matter	< 200 s	≤ 3.0 %	≤ 3.0 %

- 5.5.6 Zero and span drift check shall be performed using certified and specialized reference materials for the CEMS, such as calibration gases which are traceable to national standards and manufactured recognised by DOE. Plant operator shall ensure the availability and validity of reference materials prior checking and CEMS auditing.

- 5.5.7 Frequency of zero and span check shall be performed based on the maintenance interval specified in certification CEM (QAL1). DOE recommends a shorter interval (every 4 weeks).
- 5.5.8 The shorter time interval for zero and span checks may apply to PM CEMS that deal with high and dirty dust load which will affect QAL3 (zero and span drift) and will indicate excess emissions.
- 5.5.9 Maintenance and component checks for Gas and PM measurements shall be carried out at a defined intervals on a periodic basis (as per MCERT maintenance interval). These checks shall include the following components but not limited to:

**For Gas:**

- a) Sample probe
- b) Sampling line components
- c) Analyzer sample cells
- d) Sample pumps
- e) Gas conditioning units
- f) Calibration control system

**For PM:**

- a) Lense contamination check
- b) Blower
- c) Power & signal check
- d) Optical density - light intensity
- e) Availability of calibration block - surrogate material

- 5.5.10 Calibration gases shall be injected at the sample probe and follow the same path through the CEMS system as the pollutant gas.
- 5.5.11 Zero and Span Drift Check need to be conducted at two (2) point:
  - a) Zero gas value - between 0 to 20% of high-level value; and
  - b) Span gas value - between 80% to 100% of high-level value

High-level value is referring to 2.5 times ELV.

- 5.5.12 For particulate CEMS, surrogates for true reference materials will be required for performing zero and span checks, and these shall be tested and qualified during the type of approval (QAL 1). Plant operator shall ensure the availability and validity of reference materials prior checking and CEMS auditing and it is recommended for plant operator to keep surrogates or reference materials at site.

5.5.13 Calibration drift is calculated as percentage using the units of reference (span) gas, cell or optical filter and dividing by the span value.

$$\text{Calibration Drift(\%)} = \frac{\text{reference gas value} - \text{CEMvalue}}{\text{operating range of analyzer}} \times 100$$

For oxygen using ambient air:

$$\text{Calibration Drift(\%)} = \frac{21 - \text{CEMvalue}}{\text{operating range of analyzer}} \times 100$$

5.5.14 Frequency of checks

- a) As zero and span check measurements are recorded over time a visual representation of the zero and span deviations can be developed on the control charts allowing the process operator to assess any potential systematic changes to the CEMS.
- b) Zero and span measurements that exceed the alarm limits indicate to the process operator that the CEMS is out of control and resulting in a QAL3 failure. Hence, corrective action is required.
- c) This control chart shall be provided and developed by using any of these three (3) commonly used controls charts which are/ not limited to Shewhart, CUSUM or EWMA. **Figure 5.4** show an example of control chart.

5.5.15 The process operator shall establish procedures describing what action should be taken when these levels are exceeded. If a separate control charts to determine drift and precision have been used (such as CUSUM), adjustments can be made to the CEMS. However, any adjustment to the CEMS is not

allow if a combined chart is used to monitor both drift and precision and maintenance of system is required instead. Annex C of the EN 14181 standard provides further information covering the QAL3 process.

5.5.16 Frequency of checks

Zero and span check interval is differed by type of chart used. Recommended period is as follows:

Type of Chart	Checking frequency
CUSUM	Weekly
Shewhart	Maintenance interval specified in the QAL1*. *Shorter interval is recommended until sufficient data is available to lengthen the time between checks.

5.5.17 These following records must be made available when performing Functional Test before QAL2-CVT or AST is conducted:

- a) Zero and span check records.
- b) History of each time an alarm limit breached.
- c) Corrective actions taken

5.5.18 QAL3 Reporting

- a) QAL3 report shall be provided and made available at site whenever required by DOE during inspection. The report shall be submitted to DOE via DOE system for CEMS after the exercise is completed based on the specified maintenance interval.
- b) The QAL3 records and report shall include but not limited to the following:

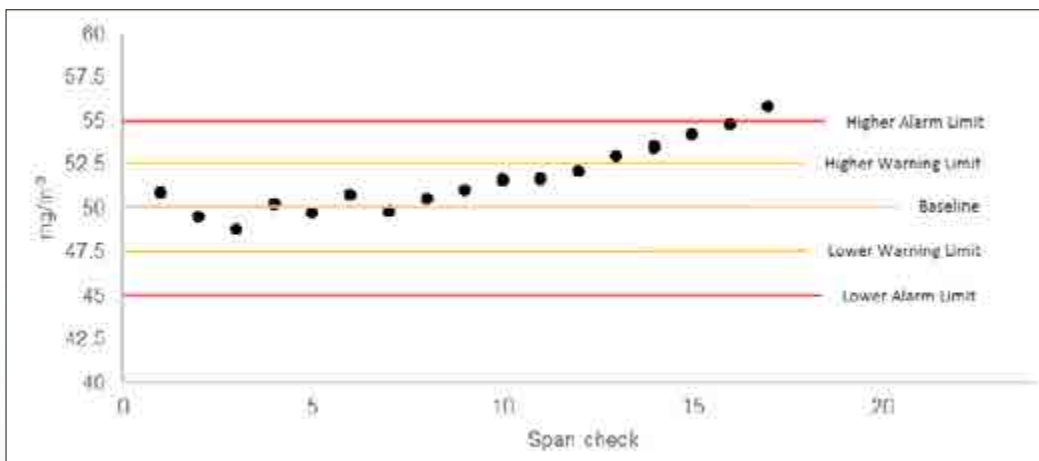

Figure 5.4 – Example of Control Chart

No.	Information	Details
1.	Plant and operation	<ul style="list-style-type: none"> <li>• Premise name</li> <li>• Information on stack with CEMS installation.</li> <li>• Source of stack emission</li> </ul>
2.	CEMS Details	<ul style="list-style-type: none"> <li>• Year of CEMS installation and operation.</li> <li>• CEMS application submission and installation approval letter.</li> <li>• Mention the make and model of the CEMS</li> <li>• Describe the monitoring approach and technique used by the CEMs.</li> <li>• Specify the operating range of the system.</li> <li>• High level value to referring to 2.5 times ELV</li> </ul>
3.	CEMS Changes	<ul style="list-style-type: none"> <li>• Details of changes made</li> <li>• Model &amp; serial number through year.</li> </ul>
4.	Plant operator's record	<ul style="list-style-type: none"> <li>• Maintenance and corrective actions</li> <li>• CEMS consultants service visit records</li> <li>• CEMS consultants call out records</li> </ul>
5.	QAL3 Procedures	<ul style="list-style-type: none"> <li>• Explain how the QAL3 procedures were carried out.</li> <li>• Highlight the zero and span gas drift checks performed.</li> <li>• Note whether the measurements were done automatically or manually</li> </ul>
6.	Results and Control Charts	<p>Include the results of the QAL3 measurements.</p> <p>Zero and span drift plots.</p> <p>Zero and span drift tabulation</p> <p>Inspect the results using control charts (e.g., Shewhart, CUSUM, EWMA) as recommended by EN 141811.</p> <p>QAL3 baseline re-sets – summary</p> <p>Compare the results against approval limits based on EN 15267 QAL1 certification test results or maximum permissible uncertainty limits defined in regulation.</p>
7.	Documentation	<p>Document the QAL3 inspection according to EN 14181 guidelines.</p> <p>Ensure that QAL3 results and any necessary repair work information are available for QAL2 and AST measurements</p>

## 5.6 Annual Surveillance Test

- 5.6.1 The Annual Surveillance Test (AST) shall carry out yearly, and its purpose is to check that the calibration function of the CEMS is still valid, and that the instrument variability is still within required limits.
- 5.6.2 The first part of AST is the Functional Test which shall be performed according to sub-chapter 5.2. The following procedures are same as Calibration and Variability Test (QAL2-CVT) described in para 5.3 but with fewer parallel SRM tests.
- 5.6.3 At least five (5) parallel measurements are required, it is advised to carry out at least one more in case a test is deemed as invalid. These measurements shall be uniformly spread over the whole measuring day.
- 5.6.4 The time interval between the start of each parallel measurement must be at least one hour and sampling time for the parallel measurement shall be at least 30 minutes.

- 5.6.5 Determine valid calibration range and carry out variability test; and then do assessment (pass-fail criteria) for variability result. (procedures are same as described in para 5.3.9 and 5.3.10)
- 5.6.6 Five (5) parallel measurements of SRT test are needed and the same flow chart as in Figure 5.2 can be referred. Only number of parallel measurements is differed from the QAL2-CVT.
- 5.6.7 The conduct of AST without CF validation as obtained from the previous QAL2-CVT is not permitted.
- 5.6.8 The Annual Surveillance Test report shall be prepared and submitted to DOE via DOE system for CEMS for verification. The test report shall be well organized, readable, and complete. All data, including softcopy and hardcopy of raw data necessary to recalculate any of the reportable parameters, shall be included in the report. Appendix 2 listed the items that are to be reported.

## 5.7 Modifications, Upgrading or Repairs of CEMS

5.7.1 Any modification, upgrading or repairs to the CEMS that results in significant changes to its components (such as sensor, analyzer or standard conditioning system) must undergo QAL2-CVT.

5.7.2 Any modification to a component that differs from the original MCERT/TÜV-certified, must undergo QAL3-OGPM. If this evaluation fails, an AST shall be conducted to verify the calibration function. However, if the AST also fails, then QAL2-CVT must be performed.



# Chapter 6 ►

## Reporting

### 6.1 Record Keeping

- 6.1.1 Plant operator must maintain a record of:
- All pertinent information, manufacturer literature, phone logs, meeting notes.
  - QA Manual containing all QC of CEMS as describe in **Table 5.1**
  - Operations and maintenance record.
  - Emission measurements, CEMS data evaluation report and quality assurance test report including Calibration and Variability Test, On-going Performance Monitoring, Annual Surveillance Test etc.
  - Excess emission reports, instrument logbooks, downtime, adjustments and maintenance.
- 6.1.2 Record display from DAHS as described in subchapter 3.4, must made available for audit and inspection.
- 6.1.3 All these records must be retained (softcopy or hardcopy) at least for 3 years as per required under the EQ (Clean Air) Regulations 2014 and made available to DOE for inspection upon request.

### 6.2 Reports

- 6.2.1 Quality Assurance Program involving Functional Test, Calibration and Variability Test and Annual Surveillance Test require report to be prepared by CEMS Tester who is appointed by plant operator. These reports shall be submitted to DOE for verification via DOE system for CEMS and the report format shall follow the following appendixes as below:
- Appendix 1 - Functional Test Audit Report
  - Appendix 2 - CVT Report / AST Report
- Functional Test Audit Report and CVT Report / AST Report shall be submitted to DOE not later than two calendar month after completion the audit exercise.
- 6.2.2 CEMS evaluation report – Plant operator shall submit the results of CEMS evaluation within three (3) months after end of each calendar year as per required under the Regulation 17 of CAR, 2014. Reporting shall be made to state or branch DOE and the reporting format is as in **Appendix 3**.

- 6.2.3 Report of Excess Emission - in the event where ELV standards exceed the prescribed limit values (emission half hour average > 2 x ELV and emission daily average > ELV), plant operator shall notify the DOE within 24 hours of such occurrence. Reporting shall be made to state or branch DOE and the reporting format is as in **Appendix 4**.
- 6.2.4 Report of CEMS failure – in the event the CEMS fails to operate, plant operator shall notify DOE not later than one (1) hour. Reporting shall be made to state or branch DOE and the reporting format is as in **Appendix 4**.
- 6.2.5 Source or CEMS shutdown – any operation or CEMS shutdown due to the scheduled maintenance work, change of parts and components, close/stop operation etc. must notify to DOE. Reporting shall be made to state or branch DOE and the reporting format is as in **Appendix 4**.
- 6.2.6 **DOE SYSTEM FOR CEMS**
- Is a system featuring information of CEMS and compliance status of industrial premise based on CEMS readings.
  - This system can be access by the CEMS Consultant, CEMS Tester, Plant Operator and DOE Officers.
  - Plant operator shall use, conduct any necessary actions and monitor CEMS reading compliance through DOE system for CEMS system.
  - As described in subchapter 3.5, data CEMS required transmission to the DOE can be viewed and accessed by DOE and plant operator through DOE system for CEMS.
  - Plant operator shall aware and notify to DOE if the CEMS data failed to be transmitted to DOE server.
  - DOE system for CEMS is developed by DOE with a feature to notify plant operator to conduct the scheduled quality assurance programs and provides alert system of any excess emission. Plant operator shall be mindful of any notification received through DOE system for CEMS and take necessary action.

# Reference

1. Environmental Quality Act, 1974
2. Environmental Quality (Clean Air) Regulations, 2014
3. Department of Standard Malaysia, Malaysian Standard MS 2564:2014 - Performance Criteria and Test Procedure for CEMS
4. Department of Standard Malaysia, Malaysian Standard, MS 1596:2003 - Determination of Concentration And Mass Flow of Particulate Matter in Flue Gas for Stationary Source Emissions
5. Environment Agency UK, 2018, Technical Guidance Note (Monitoring) - M20 - Quality Assurance of Continuous Emission Monitoring Systems - Application of EN 14181 And BS EN 13284-2
6. Environmental Protection Agency Office of Environmental Enforcement, Ireland, December 2017, Air Guidance Note on the Implementation of I.S. EN 14181
7. Environment Agency UK, 2015, Technical Guidance Note (Monitoring) - M2 -Monitoring of Stack Emissions to Air.
8. European Standard EN 15259: Requirements for Measurement Sections and Sites and for the Measurement Objective, Plan and Report.
9. European Standard EN 13284-1: Stationary Source Emissions – Determination of Low Range Mass Concentration of Dust – Part 1: Manual Gravimetric Method
10. European Standard EN 13284-1: Determination of Low Range Mass Concentration of Dust – Part 2: Quality Assurance of Automated Measuring Systems
11. Air Emission Guidance Note on CEMS Maintenance and Operation Requirement (AG13)
12. United States Environment Protection Agency 1990. Continuous Emission Monitoring System; Operation & Maintenance of Gas Monitoring – APTI Course SI:476B, Air Pollution Training Institute.
13. United States Environment Protection Agency, Performance Specification 2—Specifications and Test Procedures for SO<sub>2</sub> and NO<sub>x</sub> Continuous Emission Monitoring Systems in Stationary Sources
14. United States Environment Protection Agency, Procedure 1—Quality Assurance Requirements for Gas Continuous Emission Monitoring Systems at Stationary Sources
15. United States Environment Protection Agency, Procedure 2 - Quality Assurance Requirements for Particulate Matter Continuous Emission Monitoring Systems at Stationary Sources
16. United States Environment Protection Agency, Methods 7E – Nitrogen Oxide – Instrument Analyzer
17. United States Environment Protection Agency, Chapter 2 – Bias Due to Probe Location and Stratification

**Functional Test Audit Guidance**

A Functional test audit shall be performed on the complete CEMS sampling train before a Calibration & Variability Test (QAL2-CVT) or Annual Surveillance Test (AST) is performed, to confirm that it has been installed correctly and is working as expected. This will involve assessing the installation of the CEMS, its response to reference materials, as well as checking the On-Going Performance Monitoring process and all other relevant documentation.

The functional test audit shall be performed no more than one (1) month before the parallel measurements are started and will be carried out on a separate visit to the QAL2-CVT/AST. This is to ensure that any faults or problems that are discovered can be corrected in time. It is required to include peripheral CEMS of Oxygen and Moisture (if used) in these audits, as measurements from these systems are used to correct to standardized conditions.

The following guidance is provided to guide on performing the functional test audit, and a format report is included. Not all sections need to be completed, and the table below indicates which steps need to be executed, depending on what type of CEMS is being audited.

**Measurement Site & Installation**

A risk assessment of the work area is required prior to starting the functional test audit, and checks shall be undertaken to ensure that there are suitable provisions to carry out the functional test audit and parallel measurements later. The CEMS should have weather protection as well as enough space and safe access to perform the necessary work. Suitable tools, reference materials, and spare parts shall also be readily accessible.

**Alignment & Cleanliness**

A visual inspection of the CEMS shall be carried out. This will involve checking of the internal components, assessing the amount of contamination, and checking the alignment of the system amongst other things.

**Sampling Train**

A visual inspection of the CEMS sampling train shall be carried out by the instrument engineer or test laboratory. This will involve checking each component of the sampling train, confirming that they are working correctly, and are in good condition.

**Table 1: Functional Test Audit Requirements**

Functional test activity	Calibration & Variability Test (QAL2-CVT) & Annual Surveillance Test (AST)	
	Extractive CEMS	In-Situ CEMS
Alignment & cleanliness		/
Sampling Train	/	
Documentation and records	/	/
Serviceability	/	/
Leak Test	/	
Zero and span check	/	/
Linearity	/	
Interferences	/	/
Zero and span drift (audit on On-Going Performance Monitoring)	/	/
Response time	/	/
Report	/	/



### Leak Test

A leak test of the complete sampling train is required and shall be performed in accordance with the CEMS manual.

### Zero & Span Checks

Appropriate zero and span reference materials shall be used to check the response of the CEMS. In-situ CEMS will require a reference path free of flue gas, which may require the removal of the instrument from the stack. It shall be confirmed that the CEMS reads zero when zero concentration is applied.

### Response Time

The response time of the complete sampling train shall be assessed. Each species under test shall meet the requirement set for Calibration & Variability Test (QAL2-CVT)

### Linearity

A linearity test shall be performed on the CEMS across a range that as a minimum covers the short term ELV. The linearity will be checked using five concentrations, which includes zero, spread equally across the range using suitable reference materials.

If reference gases are used these must be traceable to approved standards. Either separate gas cylinders can be used to achieve the required concentrations, or a single gas cylinder can be used to blend to the relevant concentration using a calibrated dilution system. Some CEMS cannot use reference gases and will require suitable surrogate reference material that has been verified to perform the linearity e.g. particulate CEMS.

The linearity will be performed in a random order using concentrations at zero (twice) and approximately 20%, 40%, 60% and 80% of the range. For each change in concentration the first instrument reading shall be taken after a period of at least three response times. Three readings will be taken at each concentration, and these

readings will be separated by a period of at least four response times. A reduced time may be taken between readings to reduce the time taken for the tests, however if this results in a failure the test shall be repeated using the standard approach.

The linearity test results shall be calculated using the procedure outlined in Annex C - Malaysian Standard MS 2564:2014 - Performance Criteria and Test Procedure For CEMS

### Interferences

If there are any components in the stack gas that have been identified as interference during the QAL2-CVT process, an interference test shall be undertaken.

### On Going Performance Monitoring

An audit of the process operators' QAL3 records shall be undertaken. The assessment shall verify that suitable control charts are in place which include the results from zero and span checks undertaken since the last functional test audit, as well as a record of all alarm limit exceedance, and what action was taken to correct this.

Recommendation: QAL3 can also be initiated upon CEMS installation and operation, though QAL2-CVT is yet to be performed. This will provide pre-indication and supplement information needed by the CEMS tester in preparation for the Functional Test report.

### Documentation

The CEMS audit tester shall check that the process operator has all the required documentation such as records keeping, and the records mentioned Chapter 6 of guidelines are in place or readily available.

### Report

If any faults or problems have been identified, these shall be noted, including the required corrective action which has been undertaken. Photos of all functional test activities shall be included in the reports.

### Functional Test Audit Report Format

<p><b>Plant Operator &amp; Premise Details</b></p> <p>Company                  Plant Name:                  Plant Address:                  Mailing Address:</p>	<p><b>Type of Activity/ Process</b></p>
<p><b>Contact Person</b></p> <p>Name:                  Address:                  Position:                  E-mail:                  Contact No: (012-345678)</p>	<p><b>Installation Name</b></p> <p>Type of Equipment:                  Equipment Identification:                  Stack Identification:</p>
<p><b>Dates of Functional Test:</b></p>	<p><b>DOE Letter Reference No/Date:</b>                  Written Approval/Notification of Installation, CEMS Approval Letter, EIA Report Approval Letter or License Conditions (which ever applicable)</p> <p><b>CEMS Approval Letter</b>                  Reference Number:                  Date:</p> <p><b>EIA Report Approval Letter</b>                  Reference Number:                  Date:</p>
<p><b>Report Date:</b></p>	<p><b>Reported By:</b></p> <p>Name:                  Position:                  Company:                  Address:                  E-mail:                  Contact No:</p>

<b>CEMS Information</b>				
<b>CEMS Manufacturer and Model</b>				
<b>Registered CEMS Consultant (CEMS Supplier)</b>				
<b>Serial Number</b>				
<b>Certified No</b>				
<b>Emission Pollutant</b>	<b>Measured Unit</b>	<b>Measured Range</b>	<b>Measured Conditions</b>	<b>Current Calibration Function</b>
<b>Measurement Site &amp; Installation</b>				
<i>(Note: An assessment of the installation shall be undertaken to check the safety of working environment and suitable provisions are available and in place)</i>				
<b>In-situ &amp; Extractive CEMS</b>	<b>Check (/) or (x)</b>	<b>Notes</b>		
Is there a safe and clean working environment that has enough space and weather protection?				
Is there easy and safe access to the CEMS?				
Are tools, spares parts and reference materials available and well-kept at site?				
Are there facilities to introduce reference materials directly to the CEMS as well as through the complete system (extractive only)?		Please note whether the facilities are installed permanently or temporary based.		
<b>Alignment &amp; Cleanliness</b>				
The complete sampling train shall be visually inspected to check the alignment and cleanliness of the system				
<b>In-Situ CEMS</b>	<b>Check (/) or (x)</b>	<b>Notes</b>		
Internal check of the CEMS components				
Cleanliness of the optical				
Flushing of air supply				
Any obstructions in the optical path?				
The following shall be checked after the CEMS has been re-assembled and installed at the sampling location				
Alignment of the measuring systems				
Contamination control (internal check of optical surfaces)				
Flushing air supply				

<b>Extractive CEMS</b>	<b>Check (/) or (x)</b>	<b>Notes (The complete sampling train shall be visually inspected)</b>
Sampling probe		
Gas conditioning systems		
Pumps		
All connections		
Sample lines		
Power supplies		
Filters		
NO <sub>x</sub> converter efficiency (if applicable)		Please provide the test result
Visual inspection of sampling train		
<b>Leak Test</b>		
The complete system shall be leak tested in accordance with the CEMS manual		
<b>Extractive CEMS</b>	<b>Check (/) or (x)</b>	<b>Notes</b>
Leak Test Results		Please provide the test result here
<b>Zero &amp; Span Check</b>		
To Verify the zero and span of the CEMS using suitable reference materials. For in-situ CEMS a reference path free of flue gas is required		
<b>In-situ &amp; Extractive CEMS</b>	<b>Check (/) or (x)</b>	<b>Notes</b>
Zero Check		Please provide the test result here
Span Check		Please provide the test result here
<b>Response Time</b>		
The response time of the CEMS shall be checked through the complete sampling train, this shall not exceed the criterion specified in performance specification criteria certified for this equipment		
<b>In-situ &amp; Extractive CEMS</b>	<b>Check (/) or (x)</b>	<b>Notes</b>
Response Time		Please provide the test result here
<b>Linearity</b>		
The CEMS is tested using five (5) reference concentrations including a zero, at the inlet of the analyzer, the concentrations shall be spread over a range of at least the short term ELV and applied in a random order		
<b>In-situ &amp; Extractive CEMS</b>	<b>Check (/) or (x)</b>	<b>Notes</b>
What reference materials will be used to perform the linearity?		
Reference material information (e.g. cylinder IDs, dilution system ID, reference filter IDs)		
Reference material with zero concentration		
Reference material concentration approximately 20% of the range		
Reference material concentration approximately 40% of the range		
Reference material concentration approximately 60% of the range		
Reference material concentration approximately 80% of the range		
Reference material with zero concentration		



<b>Extractive CEMS</b>	<b>Check (/) or (x)</b>	<b>Notes (The complete sampling train shall be visually inspected)</b>
Does the CEMS pass? (The procedure is described in Annex C MS 2564:2014)		Please provide results and calculation here
<b>Interference</b> Tests shall be undertaken if there are interference in the flue gas that could influence the CEMS. These will have been identified during the QAL 1 certification process		
<b>In-situ &amp; Extractive CEMS</b>	<b>Check (/) or (x)</b>	<b>Notes</b>
Has an interference check been carried out?		

### Zero & Span Drift Audit

On-Going Performance Monitoring (based on maintenance interval) shall be carried out to check that there is a procedure in place, regular zero and span measurements are being performed and what action was taken if an On-Going Performance Monitoring failed

<b>In-situ &amp; Extractive CEMS</b>	<b>Check (/) or (x)</b>	<b>Notes</b>
Has a check of the On-Going Performance Monitoring audit been performed?		Please attach a control chart and corrective action taken (if applicable)

### Documentation

The plant operator should have access to the following records and documents

<b>In-situ &amp; Extractive CEMS</b>	<b>Check (/) or (x)</b>	<b>Notes</b>
CEMS installation and configuration drawing plan		To show probe/in-situ installation, schematic diagram, sampling train which has approved by DOE
CEMS certification information		
QA manuals		
Logbooks - Record on CEMS upset and corrective action taken		
Service reports		
On-going performance monitoring documentation (QAL3)		
Procedures for CEMS maintenance, calibration and training		
Training records		
Maintenance schedules		
Auditing plans and records		

### Report

The functional test audit shall be completed before the QAL2-CVT/AST in case any corrective action is required

<b>In-situ &amp; Extractive CEMS</b>	<b>Check (/) or (x)</b>	<b>Notes</b>
Are there any faults that require corrective action?		
Any recommendations for improvement on CEMS operation?		

**Personnel Involved with the Functional Test Audit**

Name	Company	Date	Role

**Declaration:**

It is hereby acknowledged that the CEMS Functional Test for (stack ID) of (name of equipment/process) at (plant name) was conducted as per DOE Malaysia requirement on (date of FT) by (DOE registered CEMS tester) and (DOE registered CEMS Consultant) with all information provided in this report are true and within the knowledge of the (CEMS consultant) and (DOE registered CEMS tester) testing team. Any misleading or incorrect information provided can lead to the offence under the Regulation 28 of Environmental Quality (Clean Air) Regulations 2014.

**CEMS Tester:**

**(Signature)**

**Name:**

**Company:**

**Position:**

**Date :**

**CEMS Consultant :**

**(Signature)**

**Name:**

**Company:**

**Position:**

**Date :**

I hereby acknowledge the Functional Test report as mentioned and prepared by the above-mentioned parties is within my knowledge and all information provided are true. Hence, submission of this report to DOE Malaysia is consented.

**Plant Operator (Witness):**

**(Signature)**

**Name:**

**Company:**

**Position:**

**Date :**

### Calibration & Variability Test/ Annual Surveillance Test Guidance

This report format template specifies the minimum requirements for reports for Calibration & Variability Test (QAL2-CVT) and Annual Surveillance Test (AST), as required by DOE in this guideline. It is a specification for both the contents of a report, and the order of the contents. This means that every single item included in this template must be included in the test reports for QAL2-CVT and AST. We may reject any test reports that do not comply with these requirements. CEMS tester may include additional information, and present much of the information specified below within tables. However, additional information should be within the annexes, to keep the main body of the report as short as possible. The full data and supplementary information shall be included in the Annexes.

The template is based on Microsoft Word but a CEMS tester can use any type of software provided that the minimum requirements set out in this template are included. The softcopy of raw data (Microsoft Excel format) shall be submitted together with hardcopy of this report to DOE

DOE may require additional information to verify that the procedure has been followed.

This format report template is divided into six (6) core sections and supporting Annexes, which are:

- a) Section 1 – Title Page/Executive summary;
- b) Section 2 – Information about the regulated installation, and its provisions for monitoring;
- c) Section 3 – Information about the monitoring that the test laboratory performs
- d) Section 4A – Data and calculations – QAL2;
- e) Section 4B – Data and calculations – AST;
- f) Section 5 – Results of the functional tests, and who performed the tests.
- g) Annexes
  - Any supporting data which the CEMS tester decides to include in the annexes;
  - Any supporting information about the CEMS tester, e.g. a copy of the scope of accreditation.

### Calibration & Variability Test/Annual Surveillance Test - Report Format

#### Section 1

Title Page (QAL2-CVT or AST)	
<b>Plant Operator &amp; Premise Details</b> Company Name : Plant Name : Plant Address : Mailing Address :	<b>Type of Activity/ Process</b>
<b>Contact Person</b> Name: Address: Position: E-mail: Contact No:	<b>Installation Name</b> Type of Equipment: Equipment Identification: Stack Identification:
<b>Dates of Tests/Sampling:</b> 1. CEMS Functional Checks: 2. Linearity Test: 3. Parallel Measurement SRM:	<b>DOE Letter Reference No/Date:</b> Written Approval/Notification of Installation, CEMS Approval Letter, EIA Report Approval Letter or License Conditions (which ever applicable) <b>CEMS Approval Letter</b> Reference Number: Date : <b>EIA Report Approval Letter</b> Reference Number: Date:
<b>Report Date:</b>	<b>Reported By:</b> Name: Position: Company: Address: E-mail: Contact No:

**Executive Summary**

(shall contain following summarize information & results)

- Whether the test is an AST or a QAL2;
- The stack designation;
- The emission substance;
- Value for a in the calibration function;
- Value for b in the calibration function;
- The valid calibration range based on calibrated CEMS data from the QAL2-CVT;
- The valid calibration range based on calibrated CEMS data from the AST;
- The extrapolated range based on reference materials;
- A statement of a pass or fail for the variability test (QAL2-CVT and AST);
- A statement of a pass or fail for the calibration test (AST);
- Recommendations where applicable;
- A firm statement that the calibration function, once applied, only remains valid if the On-Going Performance Monitoring data remains within control limits, and that there are no manual adjustments made to the CEMS other than those allowed to bring the settings back within the OGPM control limits.

Example Result Table:

Parameter	Calibration Function	Procedure used (a or b)	Valid Calibration Range at Ref Condition	Calibration Function Derived from Linearity (Y or N)	Assessment of Variability Test	95% Confidence Interval Requirement	Difference CEMSmeasure before calibration -SRMmeasure < 95% CI Yes/No

**Deviations**

- If there any are deviations from the SRMs, and reasons for this;
- If there any are deviations from QAL1 - certification, and reasons for this;
- Any impacts on the results;
- Any actions required;
- Any CEMS tester recommendation.

## Section 2

Information about the Regulated CEMS Installation			
<b>2.1 Information of Regulated CEMS Installation</b>			
<b>2.1.1 Name of the Installation</b>		<b>Type of Equipment :</b> <b>Equipment Identification :</b> <b>Stack Identification :</b>	
<b>2.1.2 Plant and CEMS Installation Address</b>			
<b>2.1.3 Plant Activity (CEMS-related)</b>			
<b>2.1.4 Date of Last QAL2-CVT/AST</b>			
<b>2.1.5 Information of Regulated Monitoring Parameters and ELV</b>			
Parameters	Daily ELV	½ hour ELV	Required Uncertainty (This will be expressed as a 95% confidence interval)
<b>2.2 Operational Information and Site Monitoring-Provisions</b>			
<b>2.2.1 Process type and variations in emissions.</b>			
<ul style="list-style-type: none"> <li>• Continuous or batch process - describe the operating phases. Indicate the percentage of the load of normal runs and expected variations of emissions;</li> <li>• Explain how the expected emissions and variations in the emissions influence the sampling times and duration, to capture a representative set of samples;</li> <li>• Include any other factors which would affect the monitoring results e.g. automatic zero and span operations, or low emissions values;</li> <li>• It is also essential to check historical data beforehand, to check if the emissions are at or near zero and to report these;</li> <li>• If the check reveals that the emissions are at or near zero, then include provisions to deal with these low emissions;</li> <li>• If the CEMS is reading zero, then investigate to ensure that the CEMS is working. An agreement with the client that the implications are understood and that these discussions and findings are documented.</li> </ul>			
<b>2.2.2 Type of Fuel</b>			
<ul style="list-style-type: none"> <li>• Describe the types of fuels and their proportions used during the QAL2-CVT/AST, and during a normal operating year; also, whether multiple calibration-functions are required;</li> <li>• If the process is co-incineration, then what types and proportions of fuels were used?</li> </ul>			
<b>2.2.3 Abatement</b>			
Type of abatement plant and how this affects emissions.			
<b>2.3 Monitoring Provisions at the Installation – Periodic Monitoring</b>			
<b>2.3.1 Stack and sampling ports</b>			
<b>a) Stack/Chimney Characteristic</b>			
	<b>Information</b>	<b>Value</b>	<b>Units</b>
	Shape		
	Diameter		
	Stack Height		
	Height/Length of sampling location from downstream		
	Height/Length of sampling location from upstream		

**b) Sampling Lines & Sample Point**

Information	Particulate	Gases
Sample Port Size		
Number Used		
Orientation		
Number Points/Lines		
Filtration Location		

**2.3.2 Monitoring Platform and Site Provision**

**a) Access Sampling Platform Information**

	Observation
Type	
Safe & clean working environment	
Sufficient whether protection	
Do site hold suitable tools?	
Do site stock spare part?	
Can reference gases be injected at inlet & probe?	

- Include a diagram (and preferably latest/current photographs) of the emission point, platform and location.

**2.3.3 Sample – how representative is it?**

Homogeneity assessment and stratification test finding. Please include this assessment report and attach it with DOE response.

**2.4 Continuous Emission Monitoring Systems (CEMS) at the installations**

**2.4.1 Types of CEMS for each main pollutant, oxygen and moisture**

Include a diagram (and preferably latest/current photographs) of the emission point, platform and location.	Type of CEMS	CEMS Manufacturer and CEMS Consultant	Instrument Model	Minimum Certification Range	Actual Measuring Range	Measurement Technique	QAL1 Certificate No

**2.4.2 Types of Monitoring for Peripheral Determinants**

Monitoring for temperature and pressure, and a statement whether temperature and pressure are recorded.

**2.4.3 Site Reference Material**

Provide information of pollutant, supplier, concentration range, date of manufacturer and expiration. Certificate shall attach

## Section 3

Information About the Monitoring Campaign							
<b>3.1 Stack Emission Monitoring Team</b>							
Table all the name, position, years of experience all individuals involved in SRM							
<b>3.2 Standard Reference Methods (SRM)</b>							
<b>3.2.1 SRM Equipment</b>							
Pollutant	SRM System Provider	Instrument Model	Measurement Technique	QAL1 Certificate Number	Minimum Certified Range	Operating Range	Measurement of uncertainty as 95% CI Daily Average
<b>3.2.2 Sampling Method with Subsequent Analysis</b>							
Pollutant	Standard Method		Accreditation		Laboratory		
<b>3.2.3 On-Site Testing</b>							
Pollutant	Standard Method		Accreditation		Laboratory		

## Section 4A – Data and calculation for Calibration & Variability Testing (QAL2-CVT)

### Section 4A – Monitoring data and calculations

This section specifies the minimum number of tables and charts, and the minimum requirements for each table. CEMS Tester may combine tables where data would be repeated, e.g. in Table 4.1 and 4.2, where it is necessary to convert data to standard conditions in order to determine the procedure to be used.

<b>A4.1</b>	<p><b>Table 4.1 - Raw monitoring data</b></p> <ul style="list-style-type: none"> <li>• Start and end times of each pair of data;</li> <li>• Raw CEMS results;</li> <li>• Stack/CEMS peripheral determinants for temperature, pressure, oxygen and moisture (if measured);</li> <li>• Raw SRM results;</li> <li>• SRM peripheral determinants for temperature, pressure, oxygen and moisture;</li> <li>• SRM results expressed under the same conditions as the CEMS results.</li> </ul>
<b>A4.2</b>	<p><b>Table 4.2 – Standardised monitoring data</b></p> <ul style="list-style-type: none"> <li>• Standardised CEMS results (i.e. STP, dry and to the reference O<sub>2</sub> concentration);</li> <li>• Standardised SRM results (i.e. STP, dry and to the reference O<sub>2</sub> concentration).</li> </ul>
<b>A4.3</b>	<p><b>Plot 1 – mandatory</b></p> <p>Time series of standardized CEMS versus standardized SRM data.</p>
<b>A4.4</b>	<p><b>Calculation and procedure – Elimination of outliers</b></p> <p>Outliers should be clearly indicated in the averaged raw-data set.</p>
<b>A4.5</b>	<p><b>Calculation – determination of Procedure a, b or c</b></p> <p>Justify your procedure</p>
<b>A4.6</b>	<p><b>Table 4.3 – data used to determine the calibration function</b></p> <ul style="list-style-type: none"> <li>• SRM results expressed under the same conditions as the CEMS results</li> <li>• Raw CEMS results</li> </ul>
<b>A4.7</b>	<p><b>Calculation – determination of the calibration function</b></p> <p>show 1 example base from the Table 4.3</p>
<b>A4.8</b>	<p><b>Table 4.4 – Calculation of calibrated CEMS values</b></p> <ul style="list-style-type: none"> <li>• Raw CEMS values;</li> <li>• Calibrated CEMS values, at CEMS conditions;</li> <li>• Peripheral determinants for CEMS;</li> <li>• Calibrated CEMS values, standardized.</li> </ul>
<b>A4.9</b>	<p><b>Plot 2 – mandatory</b></p> <ul style="list-style-type: none"> <li>• x-y plot of CEMS versus SRM data, both at conditions measured by the CEMS, and not standardized;</li> <li>• Calibration function, including R<sup>2</sup> value.</li> </ul>
<b>A4.10</b>	<p><b>Table 4.5 – Data used for the variability test</b></p> <ul style="list-style-type: none"> <li>• Calibrated CEMS values, standardized;</li> <li>• SRM values, standardized;</li> <li>• Difference between each pair of values;</li> <li>• Difference minus the average of the differences;</li> <li>• Difference minus the average of the differences, squared.</li> </ul>
<b>A4.11</b>	<p><b>Calculation - the variability test</b></p> <ul style="list-style-type: none"> <li>• The calculations, as set out in EN 14181;</li> <li>• The variability test;</li> <li>• Statement of the results.</li> </ul>
<b>A4.12</b>	<p><b>Plot 3 – Mandatory</b></p> <ul style="list-style-type: none"> <li>• x-y plot of calibrated, standardized CEMS data versus standardized SRM data;</li> <li>• Indication of the valid calibration range;</li> <li>• Extrapolation of the valid calibration range, using surrogates;</li> <li>• Parallel lines above and below the regression line through the standardized, calibrated CEMS values and standardized SRM values. The parallel lines should indicate the derived uncertainty (<math>\sigma</math>) of the allowable 95% confidence interval of the daily average ELV (sometimes called ‘tramlines’).</li> </ul>



## Section 4B – Data and calculation for Annual Surveillance Test (AST)

### Section 4B – Monitoring data and calculations

This section specifies the minimum number of tables and charts, and the minimum requirements for each table. CEMS Audit Tester may combine tables where data would be repeated.

<b>B4.1</b>	<p><b>Table 4.1 - Raw monitoring data</b></p> <ul style="list-style-type: none"> <li>• Start and end times of each pair of data;</li> <li>• Raw CEMS results;</li> <li>• Stack/CEM peripheral determinants for temperature, pressure, oxygen and moisture (if measured);</li> <li>• Raw SRM results;</li> <li>• SRM peripheral determinants for temperature, pressure, oxygen and moisture;</li> <li>• SRM results expressed under the same conditions as the CEM results.</li> </ul>
<b>B4.2</b>	<p><b>Table 4.2 – Standardised Monitoring data</b></p> <ul style="list-style-type: none"> <li>• Standardised CEMS results (i.e. STP, dry and to the reference O<sub>2</sub> concentration);</li> <li>• Standardised SRM results (i.e. STP, dry and to the reference O<sub>2</sub> concentration).</li> </ul>
<b>B4.3</b>	<p><b>Plot 1 – mandatory</b></p> <p>Time series of standardized CEMS versus standardized SRM data.</p>
<b>B4.4</b>	<ul style="list-style-type: none"> <li>• Calculation and procedure – Elimination of outliers</li> <li>• Outliers should be clearly indicated in the averaged raw-data set.</li> </ul>
<b>B4.5</b>	<p><b>Table 4.3 – data used to calculate the calibration function</b></p> <ul style="list-style-type: none"> <li>• Raw CEMS values;</li> <li>• The original calibration function from the previous QAL2;</li> <li>• Calibrated CEMS values, at CEMS conditions;</li> <li>• Peripheral determinants for CEMS;</li> <li>• Calibrated CEMS values, standardized;</li> <li>• Standardized SRM values.</li> </ul>
<b>B4.6</b>	<p><b>Table 4.4 – Data used for the variability test</b></p> <ul style="list-style-type: none"> <li>• Calibrated CEMS values, standardized;</li> <li>• SRM values, standardized;</li> <li>• Difference between each pair of values;</li> <li>• Difference minus the average of the differences;</li> <li>• Difference minus the average of the differences, squared.</li> </ul>
<b>B4.7</b>	<p><b>Calculation - the variability test &amp; acceptance test</b></p> <ul style="list-style-type: none"> <li>• The calculations, as set out in EN 14181;</li> <li>• The variability test;</li> <li>• The acceptance test;</li> <li>• Statement of the results.</li> </ul>
<b>B4.8</b>	<p><b>Plot 2 – Mandatory</b></p> <ul style="list-style-type: none"> <li>• x-y plot of calibrated, standardized CEMS data versus standardized SRM data;</li> <li>• Indication of the valid calibration range;</li> <li>• Parallel lines above and below the regression line through the calibrated, standardized CEMS values and standardized SRM values. The parallel lines should indicate the derived uncertainty (<math>\sigma</math>) of the allowable 95% confidence interval of the daily average ELV (sometimes called 'tramlines');</li> <li>• Extrapolation of the valid calibration range, using surrogates, if applied.</li> </ul>

## Section 5 – Results of the functional tests

<b>5.1</b>	<b>Results of functional tests</b> Attach functional test report; format as Appendix 1
------------	---

## Section 6 – Personnel Involve

<b>Personnel Involved with Calibration &amp; Variability Test/Annual Surveillance Test</b> List all the names who involve in the CVT/AST and their roles			
Name	Position/ Company	Date	Role

## Section 7 – Copies of Digital Spreadsheet

Along with the report, a digital spreadsheet containing the following information per parameter on the QAL2/AST report shall be provided :

- a) Raw data (first level data - uncorrected, uncalibrated) from CEMS before the assessment of outliers. The header of the column shall indicate the units and basis of measurement (i.e. for NO<sub>x</sub>: mg/Nm<sup>3</sup>, wet). This shall include peripheral temperature and pressure results if relevant.
- b) Raw data (as measured by the SRM) before the assessment of outliers. The header of the column shall indicate the units and basis of measurement (i.e. for NO<sub>x</sub>: ppm, dry). This shall include all necessary peripheral data to express SRM results at CEMS conditions.
- c) Sequence of calculations to show the implementation of Calibration Function. Each step of the calculation sequence shall be reported in different columns. The header of the columns shall indicate the units and basis of measurement (i.e. for NO<sub>x</sub>: mg/m<sup>3</sup> raw / Cal mg/m<sup>3</sup> / Cal mg/m<sup>3</sup> dry, O<sub>2</sub> corr / Cal mg/m<sup>3</sup> dry, O<sub>2</sub> corr, validated)
  - The applicable (previous) calibration function shall be indicated
  - The 95% CI at ELV calculation method shall be indicated.

## Section 8 - Declaration

I hereby acknowledge that the QAL2-CVT for (stack ID) of (name of equipment/process) at (plant name) was conducted as per DOE Malaysia requirement on (date of QAL2-CVT) by (DOE registered CEMS tester) and all information provided in this report are true and within the knowledge of the (DOE registered CEMS tester) testing team. Any misleading or incorrect information provided can lead to the offence under Regulation 28 of Environmental Quality (Clean Air) Regulations 2014.

### CEMS Tester:

**(Signature)**

**Name:**

**Company:**

**Position:**

**Date:**

I hereby acknowledge that the QAL2-CVT report as mentioned and prepared by the above-mentioned party is within my knowledge and all information provided are true. Hence, submission of this report to DOE Malaysia is consented.

### Plant Operator (witness):

**(Signature)**

**Name:**

**Company:**

**Position:**

**Date:**

## CEMS Evaluation Yearly Report Format

## (A) Premise General Information

Premise Information	
<b>Plant Operator &amp; Premise Details</b> Company Name : Plant Name : Plant Address : Mailing Address :	<b>Type of Activity/ Process</b>
<b>Contact Person</b> Name : Address : Position : E-mail : Contact No :	<b>Installation Name</b> Type of Equipment : Equipment Identification : Stack Identification :
<b>Operating Periods (hours)</b>	<b>Reporting Date</b>
<b>Reported By:</b> Name : Position : E-mail : Contact No :	

## (B) CEMS Information

Pollutants (including O <sub>2</sub> and moisture)	Type of CEMS	CEMS Manufacturer and CEMS Consultant	Instrument Model	Actual Measuring Range	CEMS Location

## (C) Emission Data

Please provide monthly CEMS data generated from DOE system for CEMS as attachments and provide simple data analysis report based on the data obtained. (Appendix 5)

## (D) Statement of Excess Emissions

Date	Start Time	End Time	Duration	Remarks/Reason (Start up, soot blowing, control equipment problem, etc)

**(E) CEMS Malfunction**

Date	Time	Duration	Problem (QA calibration error, Sensor Failure, etc)	Corrective Action	Date of CEMS Resumed Operation

**(F) Declaration**

On-behalf of (Premise Name), I certify that the information contained in this report is true, accurate and complete.

**(Signature)**

**(Name)**

**(Company)**

**(Position)**

.....

**(Date)**

**(Company stamp)**

Note: This declaration shall be acknowledged by the top management of the premise

## Failure and Excess Emission Report Format

## (A) Premise General Information

Premise Information	
<b>Plant Operator &amp; Premise Details</b> Company Name : Plant Name : Plant Address : Mailing Address :	<b>Type of Activity/ Process</b>
<b>Contact Person</b> Name: Address : Position : E-mail: Contact No:	<b>Installation Name</b> Type of Equipment : Equipment Identification : Stack Identification :
<b>Operating Periods (hours)</b>	<b>Reporting Date</b>
<b>Reported By:</b> Name : Position : E-mail : Contact No :	

## (B) Source of Pollutant Information

Please provide detailed information on the sources of air pollutants, stack ID, parameters, causes of the incident and the chronology of the case

**(C) Statement of Excess Emissions**

Date	Start Time	End Time	Duration	Reasons (Start up, soot blowing, control equipment problem, etc)	Corrective Action	Remarks

**(D) APCS/CEMS Failure**

Date	Time	Duration	Problem (QA calibration error, Sensor Failure, etc)	Corrective Action	Expected Date to Resume APCS/CEMS Operation

**(E) Declaration**

**On-behalf of (Premise Name), I acknowledge that the information notified in this report is true, accurate and complete. I will ensure all necessary corrective action will be taken immediately and failure in overcoming the above-mentioned situations and problems will lead to an offense under the Environmental Quality (Clean Air) Regulations 2014.**

**(Signature)**

**(Name)**

**(Company)**

**(Position)**

**(Date)**

.....

**(Company stamp)**

Note: This declaration shall be acknowledged by the top management of the premise



Appendix 5

Monthly CEMS Data Analysis Report

Parameter: \_\_\_\_

	Jan	Feb	Mar	Apr	May	June	July	Aug	Sept	Oct	Nov	Dec
1	Comply	Comply	Comply	Comply	Process Shutdown	Comply	Comply	Comply	Comply	Comply	Comply	Comply
2	Not comply	Comply	Comply	Comply	Process Shutdown	Not comply	Comply	Comply	Comply	Comply	Comply	Comply
3	Comply	Comply	Comply	Comply	Process Shutdown	Comply	Comply	Comply	Comply	Comply	Comply	Comply
4	Comply	Comply	Comply	Comply	Process Shutdown	Comply	Comply	Comply	Comply	Comply	Comply	Comply
5	Comply	Comply	Comply	Comply	Process Shutdown	Comply	Comply	Comply	Comply	Comply	Comply	Comply
6	Comply	Comply	Comply	Comply	Comply	Comply	Comply	Comply	Comply	Comply	Comply	Comply
7	Comply	Comply	Comply	Comply	Comply	Comply	Comply	Comply	Comply	Comply	Comply	Comply
8	Comply	Comply	Comply	Comply	Comply	Comply	Comply	Comply	Comply	Comply	Comply	Comply
9	Comply	Comply	Comply	Comply	Comply	Comply	Comply	Comply	Not comply	Comply	Comply	Comply
10	Comply	Comply	Comply	Comply	Comply	Comply	Comply	Comply	Not comply	Comply	Comply	Comply
11	Comply	Comply	Comply	Comply	Comply	Comply	Comply	Comply	Not comply	Comply	Comply	Comply
12	Comply	Comply	Comply	Comply	Comply	Comply	Comply	Comply	Not comply	Comply	Comply	Comply
13	Comply	Comply	Comply	Comply	Comply	Comply	Comply	Comply	Comply	Comply	Comply	Comply
14	Comply	Comply	Comply	Comply	Comply	Comply	Comply	Comply	Comply	Comply	Comply	Comply
15	Comply	Comply	Comply	Comply	Comply	Comply	Comply	Comply	Process Shutdown	Comply	Comply	Comply
16	Comply	Comply	Comply	Comply	Comply	Comply	Comply	Comply	Process Shutdown	Comply	Comply	Comply
17	Comply	Comply	Comply	Comply	Comply	Comply	Comply	Comply	Comply	Comply	Comply	Comply
18	Process Shutdown	Comply	Comply	Comply	Comply	Comply	Comply	Comply	Comply	Comply	Not comply	Comply
19	Process Shutdown	Comply	Comply	Comply	Comply	Comply	Comply	Comply	Comply	Comply	Comply	Comply
20	Process Shutdown	Comply	Comply	Comply	Not comply	Comply	Comply	Comply	Comply	Comply	Comply	Comply
21	Process Shutdown	Comply	Comply	Comply	Comply	Comply	Comply	Comply	Comply	Comply	Comply	Comply
22	Comply	Comply	Comply	Comply	Comply	Comply	Comply	Comply	Comply	Comply	Comply	Comply
23	Comply	Comply	Comply	Comply	Comply	Comply	Comply	Comply	Comply	Comply	Comply	Comply
24	Comply	Comply	Comply	Comply	Comply	Comply	Comply	Comply	Comply	Comply	Comply	Comply
25	Comply	Comply	Comply	Comply	Comply	Comply	Comply	Comply	Comply	Comply	Comply	Process Shutdown
26	Comply	Comply	Comply	Comply	Comply	Comply	Comply	Comply	Comply	Comply	Comply	Process Shutdown
27	Comply	Comply	Comply	Comply	Comply	Comply	Comply	Comply	Comply	Comply	Comply	Process Shutdown
28	Comply	Comply	Comply	Comply	Comply	Comply	Comply	Comply	Comply	Comply	Comply	Process Shutdown
29	Comply	Comply	Comply	Comply	Comply	Comply	Comply	Comply	Comply	Comply	Comply	Process Shutdown
30	Comply	Comply	Comply	Comply	Comply	Comply	Comply	Comply	Comply	Comply	Comply	Process Shutdown
31	Comply	Comply	Comply	Comply	Comply	Comply	Comply	Comply	Comply	Comply	Comply	Process Shutdown

No. of compliance day:  
 No. of non-compliance day:  
 No. of CEMS shutdown day:  
 No. of process shutdown day:  
 Max ½ hour average: mg/m<sup>3</sup>  
 Mean ½ hour average: mg/m<sup>3</sup>  
 Median ½ hour average: mg/m<sup>3</sup>  
 Maximum daily average: mg/m<sup>3</sup>  
 Mean daily average: mg/m<sup>3</sup>  
 Median daily average: mg/m<sup>3</sup>

VOLUME 1: Guidelines For The Installation & Maintenance Of Continuous Emission Monitoring Systems (CEMS) For Industrial Premises / Facilities

**Legends:**  Comply  Not comply  CEMS Shutdown  Process Shutdown

Compliances are based on Regulation 12 dan Regulations 17(3), CAR 2014.







**VERSION 8**

AIR DIVISION  
DEPARTMENT OF ENVIRONMENT

**2025**

**SERIES OF  
CONTINUOUS EMISSION MONITORING SYSTEM  
(CEMS) GUIDELINES**

**VOL. II: GUIDELINES FOR THE CEMS DATA INTERFACE SYSTEM (CEMS-DIS)**



# TABLE OF CONTENT

## Chapter 1 - Introduction

- 1.1 Background 76
- 1.2 Objectives 76
- 1.3 Assumptions 76
- 1.4 Scope of this Guideline 77
- 1.5 CEMS: Overall System Description 77

## Chapter 2 – How To Use This Guideline

- 2.1 How to use this guideline 78
- 2.2 The intended audience 78
- 2.3 Definitions 78

## Chapter 3 – Specifications for CEMS – Data Interface System (DIS) 79

- 3.1 General System Overview 79
- 3.2 Premise with CEMS and Existing PC-Based DAS System 79
- 3.3 Premise with CEMS but Without DAS System 83
- 3.4 Communications Specifications 83

## Chapter 4 - CEMS – DIS Data Coding / Handling 84

- 4.1 Introduction 84
- 4.2 Data Coding 84



## Figures

Figure 1 : CEMS and its relationship to DOE's Centralized CEMS Monitoring System	77
Figure 2 : CEMS-DIS Components	79
Figure 3 : Recommended data loading procedure	80

## Tables

Table 1 : Definitions of Fields in reading table	80
Table 2 : Definitions of Fields in reading_log table	81
Table 3 : CEMS-DIS data coding/handling standard	84

# Chapter 1 ► Introduction

## 1.1 Background

- a) This document represents

**Volume II: GUIDELINE FOR THE CONTINUOUS EMISSION MONITORING SYSTEMS – DATA INTERFACE SYSTEM (CEMS-DIS) FOR INDUSTRIAL PREMISES/ FACILITIES.**

This guideline should be read in conjunction with:

**Volume I: GUIDELINE FOR THE INSTALLATION AND MAINTENANCE OF CONTINUOUS EMISSION MONITORING SYSTEMS (CEMS) FOR INDUSTRIAL PREMISES / FACILITIES**

and  
**ENVIRONMENTAL QUALITY (CLEAN AIR) REGULATIONS 2014.**

- b) This document provides guidelines for CEMS data interfacing between DOE and industrial premises / facilities.
- c) The guidelines will assist plant operators in developing and implementing CEMS-Data Interface System (CEMS-DIS) with standard data format accessible by DOE for the purpose of data transfer and monitoring.
- d) For premises without CEMS, please refer to Volume I for full guidance on installation of CEMS and DAS. This document will then provide guidelines for the setting up of CEMS-DIS, internet communication, and data loading procedures.

## 1.2 Objectives

The main objective of this document is to provide general guidelines for the implementation of CEMS-DIS which cover the following aspects:

- a) Specifications of computer hardware and software for CEMS-DIS implementation;
- b) Specifications of communication hardware and software for CEMS-DIS implementation;

- c) Data loading requirements and procedures;
- d) Communication requirement and procedure;
- e) Specifications of file and record format; and
- f) CEMS-DIS installation, configuration and setup.

## 1.3 Assumptions

- i. The industrial premise / facility has already installed CEMS in compliance with:

**Volume I: GUIDELINE FOR THE INSTALLATION AND MAINTENANCE OF CONTINUOUS EMISSION MONITORING SYSTEMS (CEMS) FOR INDUSTRIAL PREMISES / FACILITIES**

and  
**ENVIRONMENTAL QUALITY (CLEAN AIR) REGULATIONS 2014**

and  
has fully understood the requirements of the above-mentioned guidelines.

- ii. Emission data recorded and/or analyzed at industrial premises should be at the interval of one (1) minute for gases, one (1) minute for opacity (smoke) or as required by DOE.
- iii. Industrial operators must inform DOE of any incidence may lead to incorrect or missing data, in accordance to and in conformance to data error coding as specified in this document.
- iv. Industrial premises must be pre-registered with DOE and listed in DOE CEMS registry database and should provide the following information:
- a) Name of Industrial premises;
- b) Address of Industrial premises;
- c) Plant operators (organizational chart);
- d) Power generation capacity;
- e) Permit number and limits;
- f) Process Description – source specific information;

- g) Process activity – the type & quantity of fuel burned (load factor);
- h) Installed Control devices;
- i) Exhaust Stack / Vent ID;
- j) Operation Time;
- k) CEMS type and location;
- l) CEMS analyzer types;
- m) List of parameters monitored; and
- n) A CEMS-DIS Computer that connected to internet.

## 1.4 Scope of this Guideline

- a) Specifications of computer hardware and software for CEMS-DIS implementation;
- b) Specifications of communication hardware and software for CEMS-DIS implementation;
- c) Data loading requirements and procedures;
- d) Communication requirement and procedure;
- e) Specifications of file and record format; and
- f) CEMS-DIS installation, configuration and setup.

## 1.5 CEMS: Overall System Description

- a) The general components of CEMS and its relationship to DOE's CEMS monitoring system are as illustrated by **Figure 1**.
- b) The whole system can be divided into 3 main components:
  - i. Industrial premises' CEMS equipment sensors, probes, data loggers, and data acquisition system (DAS).
  - ii. An intermediary component called CEMS Data Interfacing System (CEMS-DIS) to store data from DAS and communicate with Centralized DOE server for CEMS data transferring purposes.
  - iii. Centralized DOE's CEMS monitoring system which is a web-based application system capable of receiving and processing data from CEMS-DIS and displaying individual factory CEMS data.
- c) This document provides guidelines to the setting up of CEMS-DIS and the required infrastructures (as mentioned in paragraph 1.5 b(ii)).

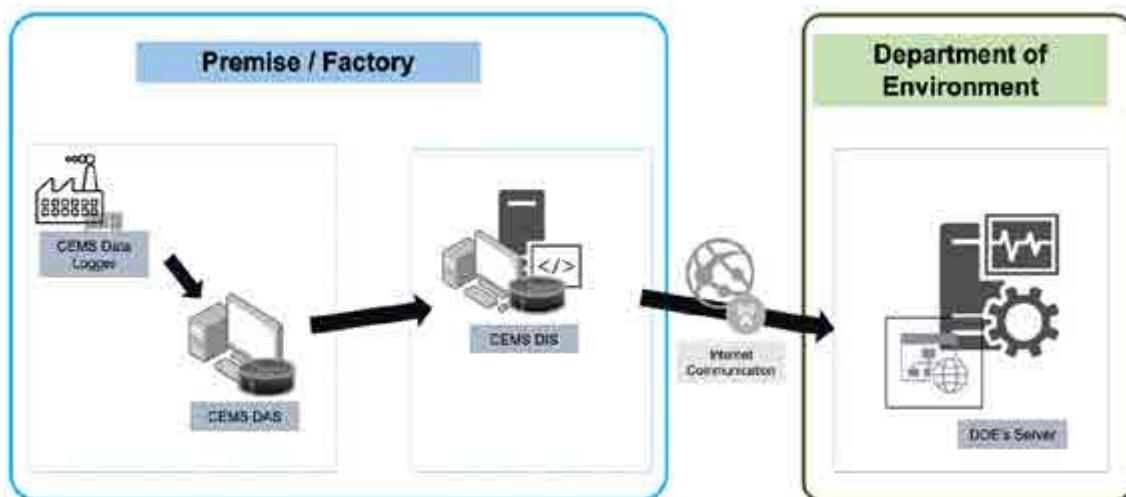

**Figure 1 - CEMS and its relationship to DOE's Centralized CEMS Monitoring System**

# CHAPTER 2 ►

## HOW TO USE THIS GUIDELINE

### 2.1 How to use this guideline

The guideline should be referred together with:

**Volume I: GUIDELINE FOR THE INSTALLATION AND MAINTENANCE OF CONTINUOUS EMISSION MONITORING SYSTEMS (CEMS) FOR INDUSTRIAL PREMISES / FACILITIES and ENVIRONMENTAL QUALITY (CLEAN AIR) REGULATIONS 2014**

### 2.2 The intended audience

This document, Volume II: Guideline for the Continuous Emission Monitoring Systems – Data Interface System (CEMS-DIS) For Industrial Premises/Facilities, is a set of guidelines for the industrial operators to set up and establish CEMS-DIS, communication between industrial premises/facilities and Centralized DOE's CEMS server, and data uploading procedures.

### 2.3 Definitions

**Broadband:** A high data-transmission rate internet connection.

**Continuous Emission Monitoring System (CEMS):** The total equipment required to sample, condition, analyze and provide a permanent computer record of pollutant concentration. This includes the equipment necessary to perform the required routine calibration and audits.

**CEMS-DIS:** CEMS Data Interfacing System is a system which consist:

- A mini-database (minimum recommendation: MySQL) to temporarily store CEMS data acquired by DAS; and
- A communication software, which is customized/ developed specifically to establish a safe and stable communication for Industrial Premises / Facilities to send CEMS data to DOE.

**Data Acquisition System (DAS):** The electronic component of the CEMS designed to interpret and convert individual output signals from pollutant concentration monitors, flow monitors, diluent gas monitors and other components of the monitoring system to produce a permanent continuous record of the measurement and desired parameters.

**DOE :** Department of Environment or Jabatan Alam Sekitar.

**DOE's CEMS Monitoring System :** a web-based application system to receive CEMS Data from industrial premises' CEMS-DIS.

**API :** Application Programming Interface, is a set of rules and tools that allows different software applications to communicate with each other.

**MySQL :** A multithreaded, multi-user, open-source SQL Database Management System (DBMS).

**PC :** Personal computer.

# CHAPTER 3 ►

## SPECIFICATIONS FOR CEMS – DATA INTERFACE SYSTEM (DIS)

### 3.1 General System Overview

- a) DOE will establish a web-based system application to receive CEMS data from industrial premises. DOE will also provide a method such as application software or API for CEMS data to be transmitted from industrial premises to DOE's CEMS Monitoring System. Instructions for using this method are provided in a separate procedural guide.

Note: The details of DOE's CEMS System will not be described in this guideline.

- b) DOE requires all relevant premises/facilities to send their CEMS data to DOE's CEMS Monitoring System.
- c) Each premise / facility must set up a Data Interfacing System (DIS) with a relational database (at least MySQL) to store CEMS data, known as the CEMS-DIS database.

Note: Please refer to **Figure 2** for CEMS-DIS Components.

- d) To avoid communication bottleneck, the sequencing and initiation of communication between premise's CEMS-DIS and DOE server will be controlled by the DOE's CEMS Monitoring System.

### 3.2 Premise with CEMS and Existing PC-Based DAS System

#### 3.2.1 Hardware Requirements for DIS Server or PC

- a) **Processor:** Minimum Intel i5 (10th Gen or later) or AMD Ryzen 5. (More threads for better multitasking and API handling)
- b) **RAM:** 8GB DDR4. (Helps with performance, if software has been running for long time and use memory heavily)
- c) **Hard Disk:** 256GB SSD (Faster than HDD, improves boot and load times, and more reliable for 24/7 usage)
- d) **Power:** An Uninterruptible Power Supply (UPS) with Automatic Voltage Regulator (AVR) is recommended. (protects data in case of power interruptions)
- e) **Availability:** The PC must be operational 24 hours a day, 7 days a week.

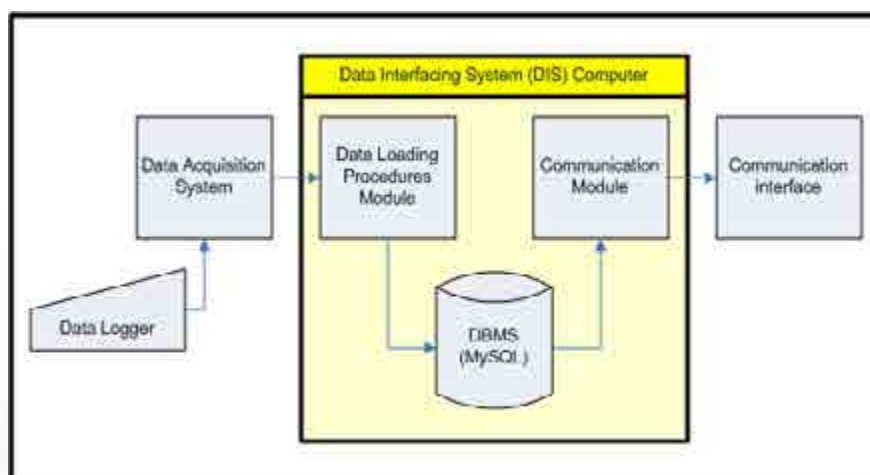

**Figure 2 : CEMS-DIS Components**

### 3.2.2 Software and Connectivity for DIS Server or PC

- a) Operating System: Windows 10 or later (Operating System must support open sources database).
- b) Database: MySQL (must support at least MySQL version 8 component library).
- c) Internet: A 24/7 internet connection, dynamic IP

### 3.2.3 Recommended Procedure for Data Loading from DAS to DIS

- a) Data uploading from DAS to DIS is within the responsibility of industrial premises or plant operators.
- b) Data uploading from DAS to DIS may be done by
  - i. Manual key-in
  - ii. Automated loading through specific application
- c) Manual key-in can be tedious, time consuming, and therefore is not recommended and not practical due to the volume of data involved.
- d) Special software can be developed for automatic loading from DAS to DIS computer. This application program can be developed by your CEMS vendor or an experienced environmental IT company.
- e) The software for automatic loading from DAS to DIS computer MUST be developed based on procedure as summarized in **Figure 3**.

### 3.2.4 CEMS-DIS Data Format and Data Structure

The industrial premises MUST FOLLOW the following requirements:

- a) All stacks monitoring data in CEMS-DIS MUST be stored in database format with the following specifications:
  - i. Database name: dis\_reading
  - ii. No. of table: 2
  - iii. Name of table: reading and reading\_log
  - iv. Field definitions for table reading please refer to **Table 1**.
  - v. Field definitions for table reading\_log please refer to **Table 2**.
- b) It is recommended that industrial premises keep the monitoring data in the CEMS-DIS database for at least five (5) year as part of data archiving.

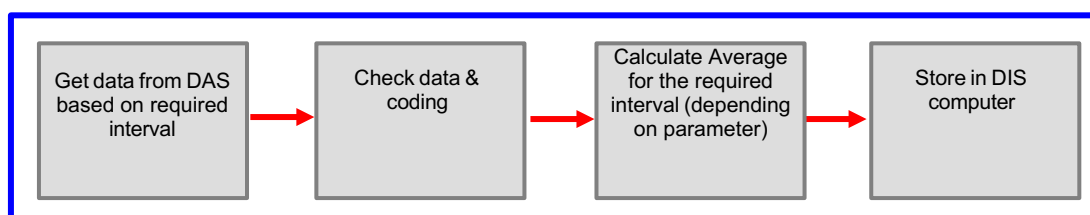

**Figure 3 : Recommended data loading procedure**

Note:

- a) Monitored data must be made available in according to DOE requirements and specification (Refer to Guideline Volume I).
- b) Data must be uploaded from DAS to DIS according to the following conditions:
  - All parameter reading is by 1-minute average. A valid 1-minute average must contain valid data readings representing any 45 seconds over the previous 1-minute period.
  - All parameter reading must be sent to DOE’s CEMS Monitoring System by every minute.
  - All parameter, except Opacity, are averaged to 30-minute interval by DOE’s CEMS Monitoring System. The 30-minute average is considered valid only when calculated from at least 22 readings (representing 75% data availability) received within that period. Otherwise, the average is considered invalid.

**Table 1 : Definitions of Fields in Reading Table**

No	Field Name	Data Type	Field Description
1.	reading_id	Integer	<ul style="list-style-type: none"> <li>primary key</li> <li>value must unique and NULL value is NOT allowed</li> </ul>
2.	factory_id	Varchar (150)	to be assigned by DOE
3.	stack_id	Varchar (150)	to be assigned by DOE
4.	read_date	Date (YYYY-MM-DD)	date of stack monitoring data
5.	read_time	Time (HH:MM:SS)	<ul style="list-style-type: none"> <li>time of stack monitoring data</li> <li>24 hour time format</li> </ul>
6.	so2	Double (5,2)	<ul style="list-style-type: none"> <li>Sulphur dioxide (SO<sub>2</sub>)</li> <li>Unit MUST in mg/m<sup>3</sup></li> </ul>
7.	no2	Double (5,2)	<ul style="list-style-type: none"> <li>Nitrogen oxides, expressed as nitrogen dioxide (NO<sub>2</sub>)</li> <li>Unit MUST in mg/m<sup>3</sup></li> </ul>
8.	co	Double (5,2)	<ul style="list-style-type: none"> <li>Carbon Monoxide (CO)</li> <li>Unit MUST in mg/m<sup>3</sup></li> </ul>
9.	co2	Double (5,2)	<ul style="list-style-type: none"> <li>Carbon dioxide (CO<sub>2</sub>)</li> <li>Unit MUST in mg/m<sup>3</sup></li> </ul>
10.	hcl	Double (5,2)	<ul style="list-style-type: none"> <li>Hydrogen Chloride (HCl)</li> <li>Unit MUST in mg/m<sup>3</sup></li> </ul>
11.	hf	Double (5,2)	<ul style="list-style-type: none"> <li>Hydrogen Flouride (HF)</li> <li>Unit MUST in mg/</li> </ul>
12.	h2o	Double (5,2)	<ul style="list-style-type: none"> <li>Water Vapour (H<sub>2</sub>O)</li> <li>Unit MUST in mg/m<sup>3</sup></li> </ul>
13.	o2	Double (5,2)	<ul style="list-style-type: none"> <li>Oxygen (O<sub>2</sub>)</li> <li>Unit MUST in %</li> </ul>
14.	nmvoc	Double (5,2)	<ul style="list-style-type: none"> <li>NMVOC as total C</li> <li>Unit MUST in mg/m<sup>3</sup></li> </ul>
15.	total_pm	Double (5,2)	<ul style="list-style-type: none"> <li>Total PM</li> <li>Unit MUST in mg/m<sup>3</sup></li> </ul>
16.	opacity	Double (5,2)	<ul style="list-style-type: none"> <li>Opacity (Smoke)</li> <li>Unit MUST in %</li> </ul>
17.	data12	Double (5,2)	New parameter
18.	data13	Double (5,2)	New parameter
19.	data14	Double (5,2)	New parameter
20.	data15	Double (5,2)	New parameter
21.	data16	Double (5,2)	New parameter
22.	data17	Double (5,2)	New parameter
23.	data18	Double (5,2)	New parameter
24.	data19	Double (5,2)	New parameter
25.	data20	Double (5,2)	New parameter
26.	data21	Double (5,2)	New parameter
27.	data22	Double (5,2)	New parameter
28.	data23	Double (5,2)	New parameter
29.	data24	Double (5,2)	New parameter
30.	data25	Double (5,2)	New parameter

Note:

- Applicable to ALL industrial premises, regardless of sector.
- Only parameters that are required by DOE to be keyed-in by industrial premises (please refer to Environmental Quality (Clean Air) Regulations 2014 for the required parameters by industrial sector)
- Information pertaining to new parameters will be disseminated to premises concurrently with the request for data submissions.

**Table 2 : Definitions of Fields in reading\_log table**

No	Field Name	Data Type	Field Description
1.	reading_id	Integer	<ul style="list-style-type: none"> <li>primary key</li> <li>value must unique and NULL value is NOT allowed</li> </ul>
2.	factory_id	Varchar (150)	to be assigned by DOE
3.	stack_id	Varchar (150)	to be assigned by DOE
4.	read_date	Date (YYYY-MM-DD)	date of stack monitoring data
5.	read_time	Time (HH:MM:SS)	<ul style="list-style-type: none"> <li>time of stack monitoring data</li> <li>24 hour time format</li> </ul>
6.	so2	Double (5,2)	<ul style="list-style-type: none"> <li>Sulphur dioxide (SO<sub>2</sub>)</li> <li>Unit MUST in mg/m<sup>3</sup></li> </ul>
7.	no2	Double (5,2)	<ul style="list-style-type: none"> <li>Nitrogen oxides, expressed as nitrogen dioxide (NO<sub>2</sub>)</li> <li>Unit MUST in mg/m<sup>3</sup></li> </ul>
8.	co	Double (5,2)	<ul style="list-style-type: none"> <li>Carbon Monoxide (CO)</li> <li>Unit MUST in mg/m<sup>3</sup></li> </ul>
9.	co2	Double (5,2)	<ul style="list-style-type: none"> <li>Carbon dioxide (CO<sub>2</sub>)</li> <li>Unit MUST in mg/m<sup>3</sup></li> </ul>
10.	hcl	Double (5,2)	<ul style="list-style-type: none"> <li>Hydrogen Chloride (HCl)</li> <li>Unit MUST in mg/m<sup>3</sup></li> </ul>
11.	hf	Double (5,2)	<ul style="list-style-type: none"> <li>Hydrogen Flouride (HF)</li> <li>Unit MUST in mg/</li> </ul>
12.	h2o	Double (5,2)	<ul style="list-style-type: none"> <li>Water Vapour (H<sub>2</sub>O)</li> <li>Unit MUST in mg/m<sup>3</sup></li> </ul>
13.	o2	Double (5,2)	<ul style="list-style-type: none"> <li>Oxygen (O<sub>2</sub>)</li> <li>Unit MUST in %</li> </ul>
14.	nmvoc	Double (5,2)	<ul style="list-style-type: none"> <li>NMVOG as total C</li> <li>Unit MUST in mg/m<sup>3</sup></li> </ul>
15.	total_pm	Double (5,2)	<ul style="list-style-type: none"> <li>Total PM</li> <li>Unit MUST in mg/m<sup>3</sup></li> </ul>
16.	opacity	Double (5,2)	<ul style="list-style-type: none"> <li>Opacity (Smoke)</li> <li>Unit MUST in %</li> </ul>
17.	data12	Double (5,2)	New parameter
18.	data13	Double (5,2)	New parameter
19.	data14	Double (5,2)	New parameter
20.	data15	Double (5,2)	New parameter
21.	data16	Double (5,2)	New parameter
22.	data17	Double (5,2)	New parameter
23.	data18	Double (5,2)	New parameter
24.	data19	Double (5,2)	New parameter
25.	data20	Double (5,2)	New parameter
26.	data21	Double (5,2)	New parameter
27.	data22	Double (5,2)	New parameter
28.	data23	Double (5,2)	New parameter
29.	data24	Double (5,2)	New parameter
30.	data25	Double (5,2)	New parameter
31.	log_timeCreated	Timestamp	Timestamp for log created
32.	log_error	Varchar (150)	Return respond of error from DOE



### 3.3 Premise with CEMS but Without DAS System

For industrial premises / facilities with CEMS but without a DAS, they must install a PC based data logger and then follow the steps below for the development of a CEMS-DIS system:

- a) If data is in analogue format, industrial premises must have a proper analogue-digital converter. This analogue-digital converter (data logger) is available in the market.
- b) When the data is ready in DAS, refer to Section 3.2 on how to set up DIS.

### 3.4 Communications Specifications

Industrial premises shall maintain continuous 24-hour Internet connectivity to support system operations and data transmission.



# CHAPTER 4

## CEMS – DIS DATA CODING / HANDLING

### 4.1 Introduction

This section provides data coding guidelines for handling of CEMS-DIS data in the event during which data could not be logged and/or transmitted to centralized DOE's CEMS Monitoring System.

### 4.2 Data Coding

- a) Please note that the exact codes must be entered correctly as specified in this guideline to ensure the system in DOE can record and interpret the missing data event precisely.
- b) All NULL values in parameter fields (either not monitored, missing, unrecorded) must be coded with an appropriate value as specified in the guideline to ensure that the DOE get a complete, comprehensive, accurate and precise data on the factory premise's stack monitoring data.
- c) The standard data coding/handling of CEMS-DIS data are shown in **Table 3**.

**Table 3 : CEMS-DIS data coding/handling standard**

No	Event	Code
1	Parameter not required and parameter not monitored by DOE	null
2	Invalid value	null

Note:

- a) The above is applicable to ALL industrial premises, regardless of sector.
- b) Invalid data definition:
  - i. The 1-minute average reading less than 45 seconds over the previous 1-minute period.
  - ii. Negative value data.
  - iii. NULL value data.



For any enquiry, kindly contact:

**Director of Air Division**

Department of Environment  
Ministry of Natural Resources and Environment Sustainability  
Level 1 - 4, Podium 2 & 3  
No.25, Wisma Petra, Precint 4  
Federal Government Administrative Centre  
62574 Putrajaya

**Director of IT Division**

Department of Environment  
Ministry of Natural Resources and Environment Sustainability  
Level 1 - 4, Podium 2 & 3  
No.25, Wisma Petra, Precint 4  
Federal Government Administrative Centre  
62574 Putrajaya









**Department of Environment**  
**Ministry of Natural Resources and Environmental Sustainability**

Level 1-4, Podium 2 & 3  
No. 25, Wisma Petra, Precint 4  
Federal Government Administrative Centre  
62574 Putrajaya

Hotline: 1-800-88-2727  
Tel: 03-8871 2000 / 2200  
Faks: 03-8888 9987 / 03-8889 1040

[www.doe.gov.my](http://www.doe.gov.my)



Jabatan Alam Sekitar